

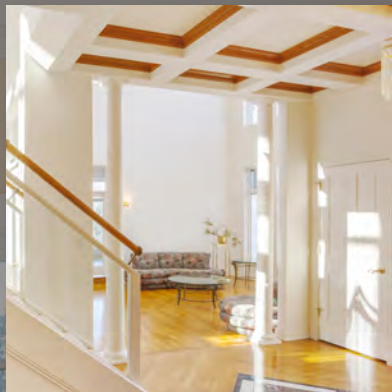

Kelleher
CORPORATION

MOULDING • LUMBER • DOORS



MOULDING CATALOG and Design Guide

NORTHERN EDITION

WWW.KELLEHER.COM



A stylized map of California is overlaid on the page. It features several white stars with black outlines indicating office locations: one in the San Francisco Bay Area, one in the Sacramento region, one in the Central Valley, one in the Southern California region, and one in the Sonoma region. The map is semi-transparent, allowing the background image of a room with a window and a light fixture to be visible.

CORPORATE HEADQUATERS

1543 Fifth Avenue, San Rafael, CA 94901
Ph (415) 454-8861 / Fx (415) 453-1003

DISTRIBUTION CENTERS

Blackpoint:

10 Grandview Avenue, Novato, CA 94945
Ph (415) 898-6366 / Fx (415) 898-5866

Sonoma:

221 Fremont Drive, Sonoma, CA 95476
Ph (707) 938-1050 / Fx (707) 938-5825

Sacramento & Central Valley:

201 Opportunity Street, Sacramento, CA 95838
Ph (916) 561-2860 / Fx (916) 561-2861

Southern California:

4774 E. Airport Drive, Ontario, CA 91761
Ph (909) 635-1560 / Fx (909) 635-1590

Hawaii:

91-241 Kalaeloa Blvd #B, Kapolei, HI 96707
Ph (808) 833-1802 / Fx (808) 833-2342

Sonoma Door Division:

221 Fremont Drive, Sonoma, CA 95476
Ph (707) 938-1050 / Fx (707) 938-5825

www.kelleher.com / info@kelleher.com

Contents

INTRODUCTION

The Kelleher Corporation	II
Environmental Policy	IV

TYPES OF MOULDING, SPECIES AND FINISHES

Material, Species and Finishes	2
Types of Moulding and Usage	5–6

DESIGN AND STYLE GUIDE FOR MOULDING AND TRIM

Introduction	8
Classic Through Contemporary Styles	9–23
Moulding Applications and Usage Ideas	24–30

MDF MOULDINGS

Base Moulding	34
Door and Window Casing, Chair Rail	50
Crown and Ceiling Moulding	61
Caps, Wainscotting	77
Door and Window Stools, Sills	80
S4S, Boards, Shelving	82

PRIMED PINE MOULDINGS

Base Moulding	88
Door and Window Casing, Chair Rail	99
Crown and Ceiling Moulding	111
Stops, Caps, Trim, S4S	121
Wainscotting & Shiplap	126
Boards, Jamb and Framestock, Stools, Sills	128

EXTERIOR MOULDING

Crowns, Pediments, Trim, Decorative Moulding	135
Utility Moulding and Handrails	139

STAIN GRADE MOULDINGS

Base Moulding	144
Door and Window Casing, Chair Rail, Crowns	150
Miscellaneous Trim, Stops, Caps, Handrails, Utility Moulding	162

ADDITIONAL KELLEHER PRODUCTS

Advantage Plus Siding	180
Lumber & Boards	182
Flexible Moulding	183
Columns	184
Doors	186

The Kelleher Corporation



A History of Quality and Service

Since 1970, the Kelleher Corporation has been a leader in the moulding and lumber industry and today is one of the largest distributors of wood moulding and accessories in the western United States. We represent some of the finest wood moulding mills in the United States and throughout the world, to provide a diverse range of products at affordable prices.

With over 200 employees and a large network of sales and distribution facilities, Kelleher is dedicated to providing retailers with a reliable supply of high quality products and excellent customer service. This commitment to our founding principles is still visible today and continues to lay the foundation for our future success.

Please take a moment to visit our website at www.kelleher.com and learn more about how Kelleher can be of service to you.

Product Information & Symbols Found in the Catalog

Part # References contained in the catalog are as follows:

P218FJ 1/2 x 2-1/4 PRIMED PINE
 (Part#) (Dimensions) (Species/Material)

The part number prefix "P-" indicates the item is Pine, the number "218" identifies the pattern, the suffix "FJ" indicates the item is a product of fingerjointed sections of pine instead of solid. The dimensions are expressed width, then height, followed by a description of the product.

Additional Part # Prefixes

- | | |
|---------------------------------|-----------------------------------|
| "P" = Pine | "MDF" = Medium Density Fiberboard |
| "CP" = Certified Renewable Wood | "F" = Douglas Fir |
| "PF" = Pine Frame | "VG" = Vertical Grain Douglas Fir |
| "PJ" = Pine Jamb | "M" = Mahogany |
| "PT" = Pine Trim | "O" = Oak |
| "C" = Cedar | "P" = Poplar |
| "ALD" = Alder | "WHW" = White Wood |
| "KALD" = Knotty Alder | |
| "EX" = Exterior Treated | |

Additional Part # Suffixes

- | | |
|---|-----------------------------------|
| "...PR" = Primed Mouldings | "...K" = Kerfed Mouldings |
| "...PPR" = Premium Primed Mouldings | "...FJ" = Fingerjointed Mouldings |
| "...FJK" = Fingerjointed & Kerfed Mouldings | |
| "...A" = Advantage Primed | |

How This Catalog is Organized

This catalog is organized primarily by type of wood moulding and finish and in the following sections:

Types of Moulding Species and Finishes looks at various ways mouldings are fabricated and prepared for consumer use.

Design and Style Guide for Moulding and Trim discusses major styles that have been influenced by historical architectural movements, and hybrid styles that are in use today.

Paint Grade mouldings include Primed Fingerjointed Pine, Medium Density Fiberboard, and Exterior Moulding

Within each of the sections mouldings appear in order of width or height, from small to large. Additional sizes of each are shown in italics underneath each of the part listings.

Stain Grade mouldings are made of natural wood suitable for staining or natural finishing.

Additional Kelleher Products section includes some of the other categories that we distribute in the region.

Photos and Historical References

Throughout this catalog we have attempted to show a wide variety of moulding styles and treatments we believe customers might want to consider for their homes. The photographs shown are for reference purposes and do not always represent specific mouldings available from Kelleher Corporation. We encourage customers to experiment and try building up moulding to achieve a desired look.



The Kelleher Corporation

Environmental Policy

ENVIRONMENTAL POLICY

The Kelleher Corporation is one of the largest distributors of the forest products industry in the western United States. We at Kelleher are deeply committed to enhancing professionalism within our industry sphere and the efficient distribution of the products we sell. The Kelleher Corporation supports those suppliers who use sustainable forest management practices, which integrate the world's social, economic and environmental needs.

The Kelleher Corporation salutes all those who use sound environmental practice. We endorse the significant efforts being made within the forest products industry to assuage the public's environmental concerns through the development and implementation of scientifically based forest product certification programs. We view the wise and prudent use of renewable resources as a cornerstone to the world's long term building products needs, and support those firms and organizations that embrace these practices.

In accordance with the above policy, it is our intent to inform and educate our customers on those organizations that are developing and promoting forest products management certification programs. Accordingly, we recognize that the Forest Stewardship Council (FSC), and the Sustainable Forestry Initiative (SFI) are two of the leading programs using sound, scientifically based management principles in promoting sustainable forestry practices.

The Kelleher Corporation – SCS Certification # SCS-C-00161
Member Since: 03/2000





**TYPES OF MOULDING,
SPECIES & FINISHES**

Wood Species, Materials, and Finishes

Solid Pine



Solid pine, or stain grade pine, is one of the original moulding substrates that can be painted or stained. The grain of this "solid" piece of wood is continuous for stained or natural finishes. Solid pine is also used in many smaller profiles and other applications where the strength of the piece is important. Solid pine mouldings are sold in random lengths.



Fingerjointed Pine



Fingerjointed pine is a paint grade product. It is made by trimming defects from common grade lumber to make short lengths of clear lumber. These pieces are then glued into longer lengths and manufactured into mouldings. This procedure helps reduce the tendency of the piece to twist or warp. They usually cost less than the stain grade equivalent because less expensive wood is used in the beginning of the process. Fingerjointed mouldings allow you to prime and paint with your own choice of oil, lacquer, or acrylic based products.

Primed Pine



Primed pine is identical to fingerjointed pine except it has a machine applied primer coat of paint. Final finishing only requires applying a top coat of paint. Pre-priming at the mill is designed to be less expensive than painting by hand, and saves time on the job.



Premium Primed Pine



Premium Primed pine is similar to fingerjointed pine except it has three coats of factory applied primer for an ultra-smooth surface, virtually eliminating visible joints and grain. Premium Primed pine is lighter and easier to cut and install than MDF. Apply a top coat of good quality acrylic or oil based paint for an elegant, professional finish.

The Premium Primed mouldings in our Signature Series are available in three distinct collections of matching bases, casings and crowns for customer convenience.

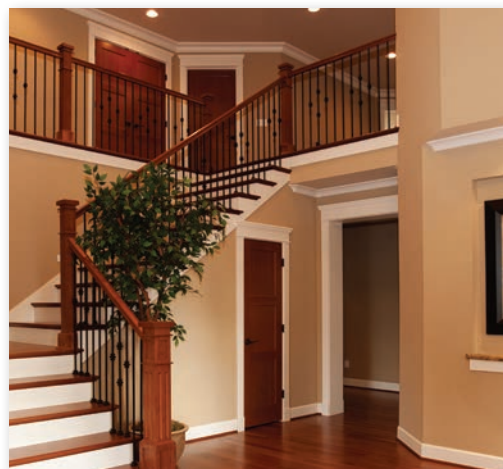

Medium Density Fiberboard



MDF mouldings are manufactured from medium density fiberboard. These mouldings are used in paint grade interior applications. The manufacturing process insures a uniform consistency without the imperfections that may exist in other paint grade products. MDF does not warp or split and does not expand and contract like natural wood species. MDF has a hard surface that will not damage easily and that will not show raised grain. MDF mouldings are usually primed and there is very little surface preparation required for finishing. They are less expensive than other wood paint grade mouldings, especially in larger architectural profiles.

Solid Oak



Oak mouldings are stain grade hardwood mouldings. They can be stained to match oak cabinetry or furniture. Oak is a hardwood that is very resistant to wear. Oak mouldings often add value to the home.





Douglas Fir



Douglas fir mouldings are used in situations requiring high durability and are often a first choice for stain grade products. In the area of durability, Douglas fir is used for closet pole and handrails. In the area of stain finishes, Douglas fir is often used in the manufacture of entry doors and is frequently chosen for use in door jambs to match the door. It is also offered in vertical grain mouldings for other stain grade applications.

Poplar



Poplar mouldings are a hardwood moulding frequently used for paint grade applications but can be used for stain grade applications. Poplar mills very cleanly with very sharp detail, a characteristic of hardwoods. As a stain grade, poplar can be stained to match a variety of woods.



Alder / Knotty Alder



Alder mouldings are a stain grade product where the final product shows off the characteristics of the wood, rather than hiding them behind paint and putty. Alder is a hardwood that can be milled with great detail.

Knotty Alder has similar characteristics to Alder though it shows more knots from where branches once protruded.



Redwood/Cedar/Exterior Treated Pine



Redwood, Cedar, and Exterior Treated mouldings are used primarily in exterior applications where durability is important. Primed and fingerjointed exterior mouldings help reduce the cost of the finished product by saving time and money in the manufacturing process. Solid redwood is used in both exterior and interior applications where the natural look or the durability of redwood is important.



About Moulding and Trim

Moulding and trim have adorned our homes and public buildings for several hundred years. Moulding and trim provide our living spaces with a finished look, and are a means to make an aesthetic statement or artistic expression. Mouldings also serve a useful purpose by connecting the different elements of building such as wall surfaces to flooring, and door and window openings. Early plaster often cracked where the ceilings met the wall, making crown and cornice mouldings a useful decoration. Early construction techniques allowed moisture to collect in the lower parts of a room or house, creating a need for wainscoting and other finished wall treatments. Chair rails and base mouldings protect walls from sliding furniture and other wear. Picture moulding was used originally by prosperous Americans as a way to display art and to break up larger wall areas.



Types of Moulding

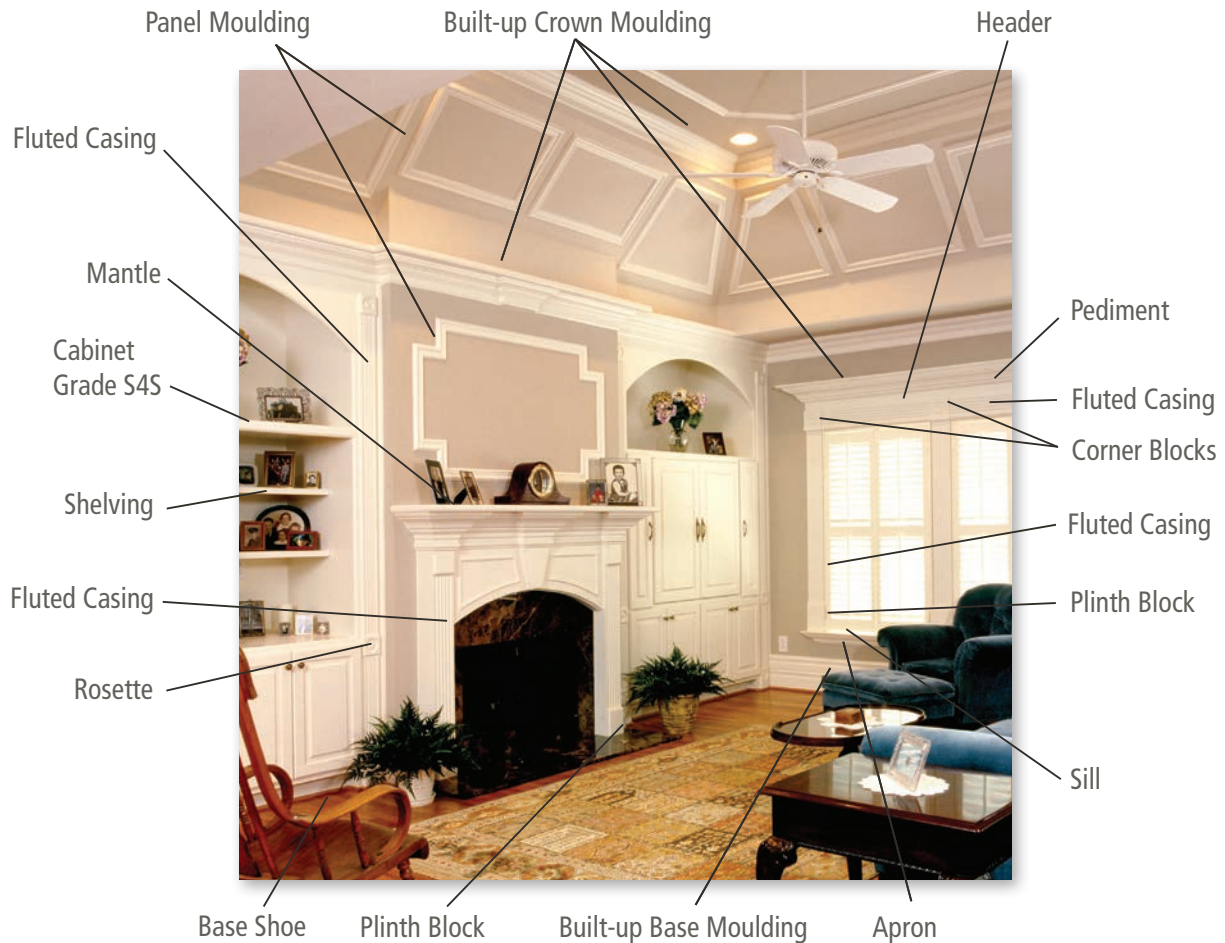

Base Mouldings serve as the finishing cover as the wall joins the floor. Many of the panel mouldings will also make two-piece baseboard applications.

Base Shoe Mouldings typically connect the base moulding to hardwood floor to finish the look and eliminate drafts.

Casings are employed as trim elements around doors and windows. In addition, they are often used as larger chair rails or linear banding around a room. A fluted casing, often with beads on the reverse side, is a popular style for classic and Victorian home decor as shown above.

Crown and Pediment Mouldings are applied where the wall joins the ceiling. They are used to add more interest and design depth to a room. Cornice mouldings themselves can be enhanced by adding other trim pieces, particularly effective when used in larger rooms with high ceilings.

Corner Blocks and **Rosettes** are used at the corners of a top casing. Paired with plinths, they can set the perfect frame shape to a door.

Door Header, Pediment and **Top Cap** are found above doors and windows. They run horizontally on top of mitered casings to give height to the opening or at the head jamb of an opening with casing. Door headers can also be used in fireplace mantle applications.

Plinth Blocks are used at the edge where a baseboard joins the casing of a doorway. Lending themselves to both stock and custom applications, they can add the right finishing touch to a dramatic entrance.

Panel Mouldings are used to form panels on ceilings and walls and enhance cornice applications. In addition, they can also be used as finer chair rails or with baseboard caps to form two-piece baseboards.

Chair Rails (not shown) are usually applied to a wall horizontally, approximately 30 to 40 inches parallel to the floor. Traditionally found in dining rooms, they protect walls from sliding furniture. Chair rails are also used as panel mouldings to trim the tops of panels on walls or ceilings, and provide a "wainscot" appearance.



**DESIGN AND STYLE GUIDE
FOR MOULDING AND TRIM**

Classic and Colonial Inspired Styles

Colonial, Federal, Georgian





Where do Moulding Styles Come From

Many of the wood mouldings we have today have roots in the rich styles of Colonial America in the 1700's. The early colonists brought with them elements of the popular Georgian styles from Europe. As their new democracy flourished, however, they developed a taste for newer architectural looks based on classic Greek and Roman forms.

Colonial trim tends to be simple yet elegant, reflecting the hand crafted production methods of the day. Many mouldings from this period are built-up using several mouldings, especially in rooms with higher ceilings where scale is important. The amount of detail and the overall level of built-up trim was also influenced by the person's or institution's place in society and, more often than not, what they could afford.

Whether you own a home of this style or just wish to recreate a historical look, a variety of mouldings are available to help you achieve your goals.

869

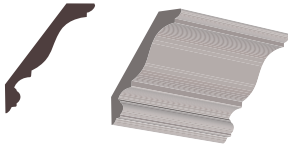

285 or 287

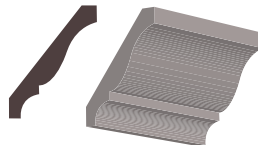

707
707/DNTL

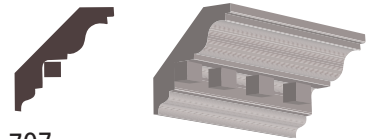

390

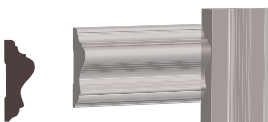

390

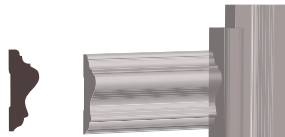

136

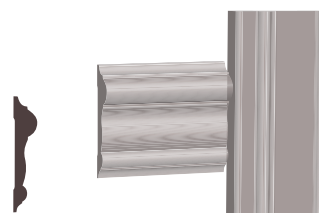

241



383
241



391



026



26

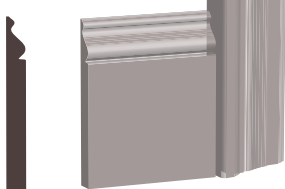

217



Moulding numbers are based on Kelleher part numbers and may be available in several species of wood. Ask your retailer about specific patterns.

Styling Clues

Styling clues of Colonial and early American styles are the extensive graceful curves and coves that form "Ogee" or "Cyma" edges found in ancient Greek and Roman architecture. The ogee curve is an analogue of a "cyma curve", the difference being that a cyma has horizontal rather than vertical ends. The early colonists sought to visually express the roots of their new-found democracy using forms of one of civilization's earliest democracies.

Another clue to this era are larger flat surfaces in baseboard mouldings and casings. A lot of the moulding in this era was crafted by hand. It was very common to apply one or more decorative edges or beads to the bottom and an ornate cap to the top of a piece of flat wood stock.

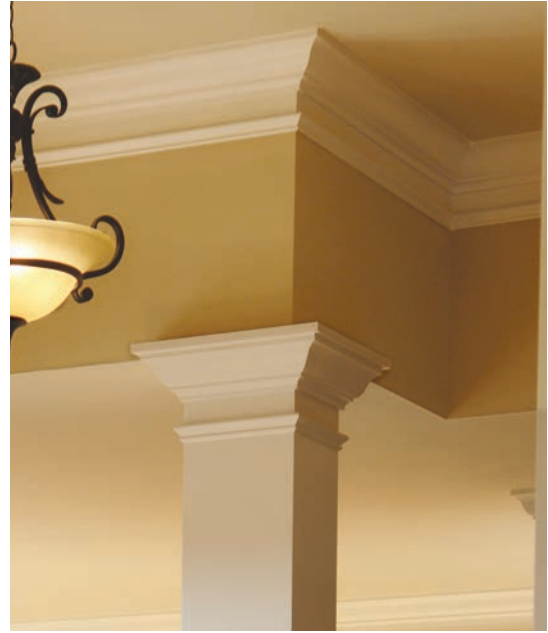

287

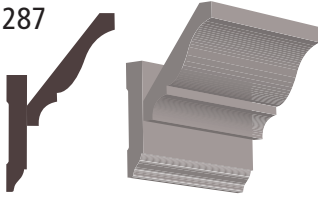

221

700

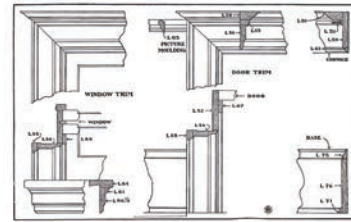
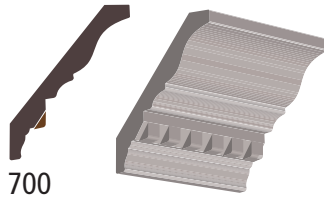

382

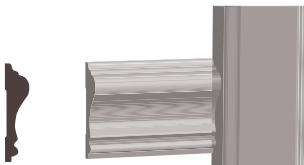

136

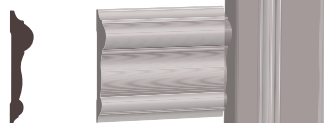

383

221 or 223



391

268



391

217

226

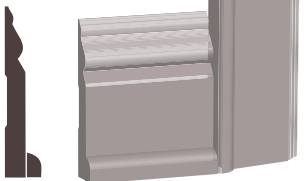

116

226



374

240

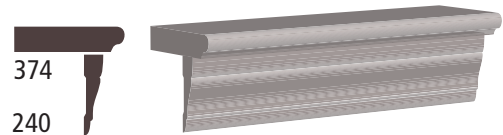



Federal and Classical Influences

After the wars of independence (1776 & 1812), Americans became more comfortable in their standing and assertive in their style. Columns, pilasters, and decorative friezes and ornaments were increasingly used on many wall treatments. Wainscoting began to appear in more rooms. Mouldings in the pre-Civil War South gradually became more decorative as the society flourished. Wealthier plantation homes reflected both Classical and European styles.

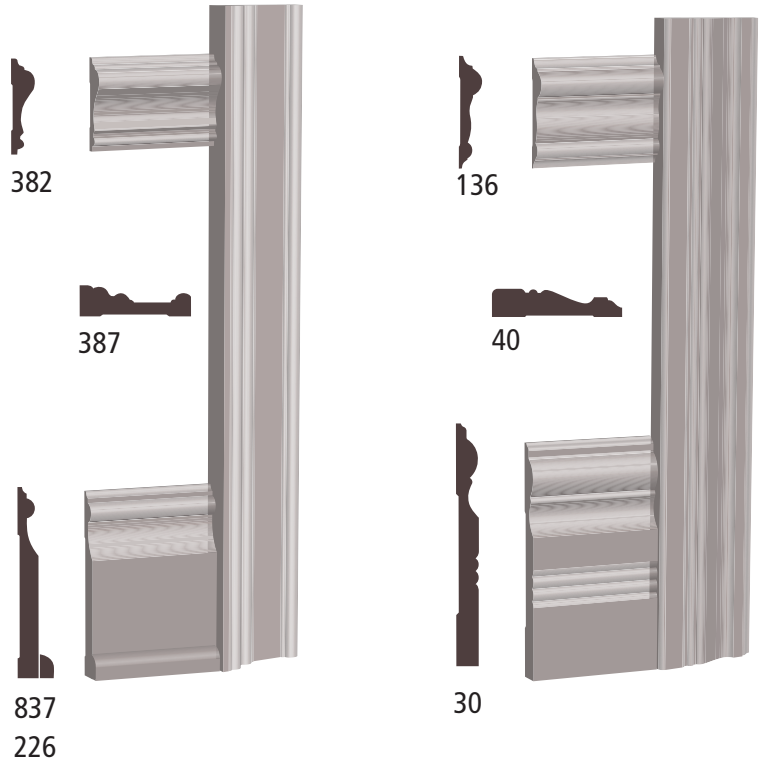
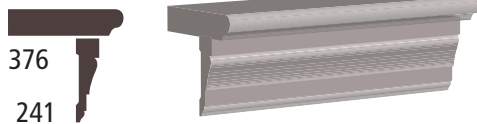
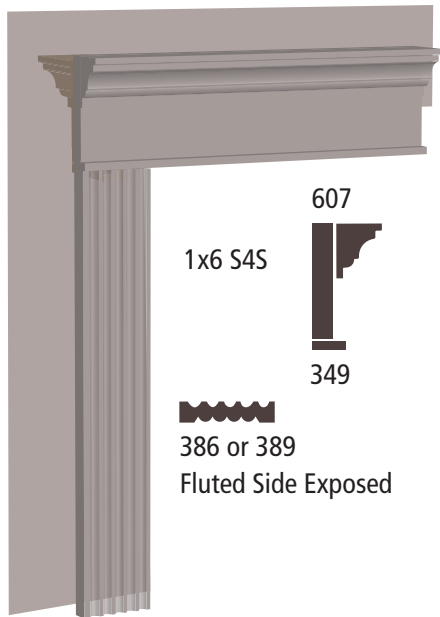
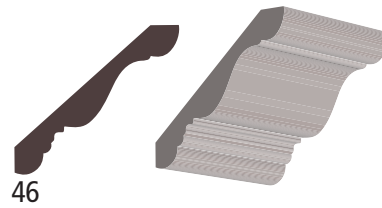
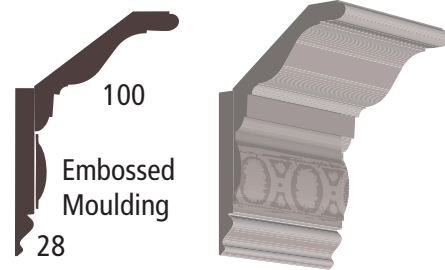

Moulding numbers are based on Kelleher part numbers and may be available in several species of wood. Ask your retailer about specific patterns.

Victorian and Other Periods of Grandeur

Queen Anne, Italianate, Revival





Victorian Styling Cues:

The Victorian Era in the Western United States actually encompasses several styles: American Victorian, Queen Anne, Italianate, and others. Many of the famed San Francisco Victorians are actually of the Italianate style.

Victorian Era mouldings generally have more detail and complexity, and rely less on the classic Greek and Roman forms. This reflected the zeal and grandeur of the industrial revolution. Industrialization made it possible to produce mouldings that were larger and had more detail. Transportation allowed abundant timber resources to be moved great distances for milling. The homeowners of this era, especially the growing middle classes, wished to reflect their status and wealth in the elaborate entry ways and public rooms of their homes.

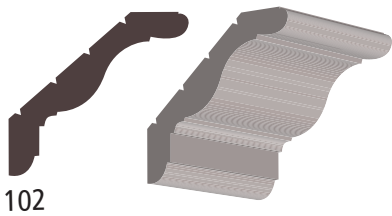

102

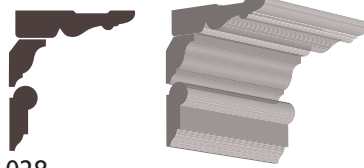

028
282
322

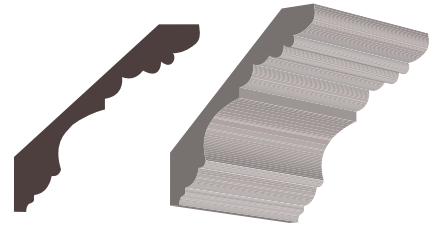

104

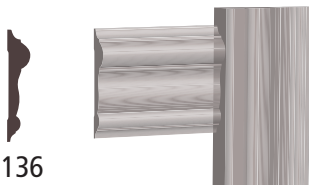

136

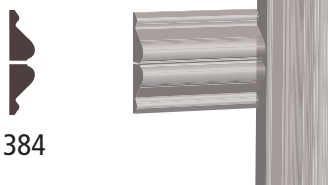

384

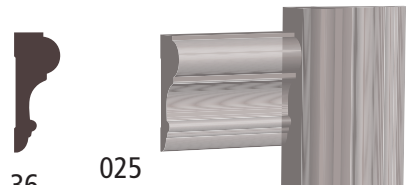

36



380



262



025

028

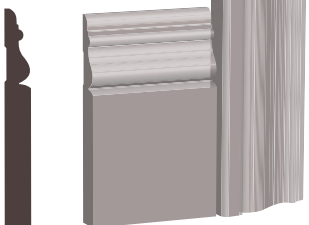

22

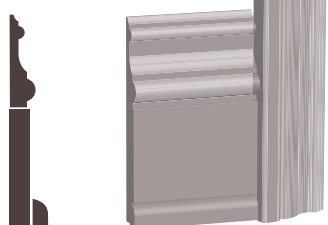

021 Cap
1x6 S4S
226



031
226



The Victorian “Three Part Wall”:

Moulding treatments from the Victorian era continued to be built-up from several mouldings, especially in larger rooms and entry/stair wells with higher ceilings. In higher ceiling rooms, picture rails emerge to add visual interest to higher walls, and provide homeowners a means to hang their newly acquired art without damaging the plaster or fabric wall treatments of the day. Ornaments and carved patterns or Friezes were used more abundantly. Wainscotting walls to the chair rail or plate rail height was common in entry ways and other public rooms. Wainscotting also protected the walls from moisture that would accumulate in the lower areas of non insulated walls of that period.

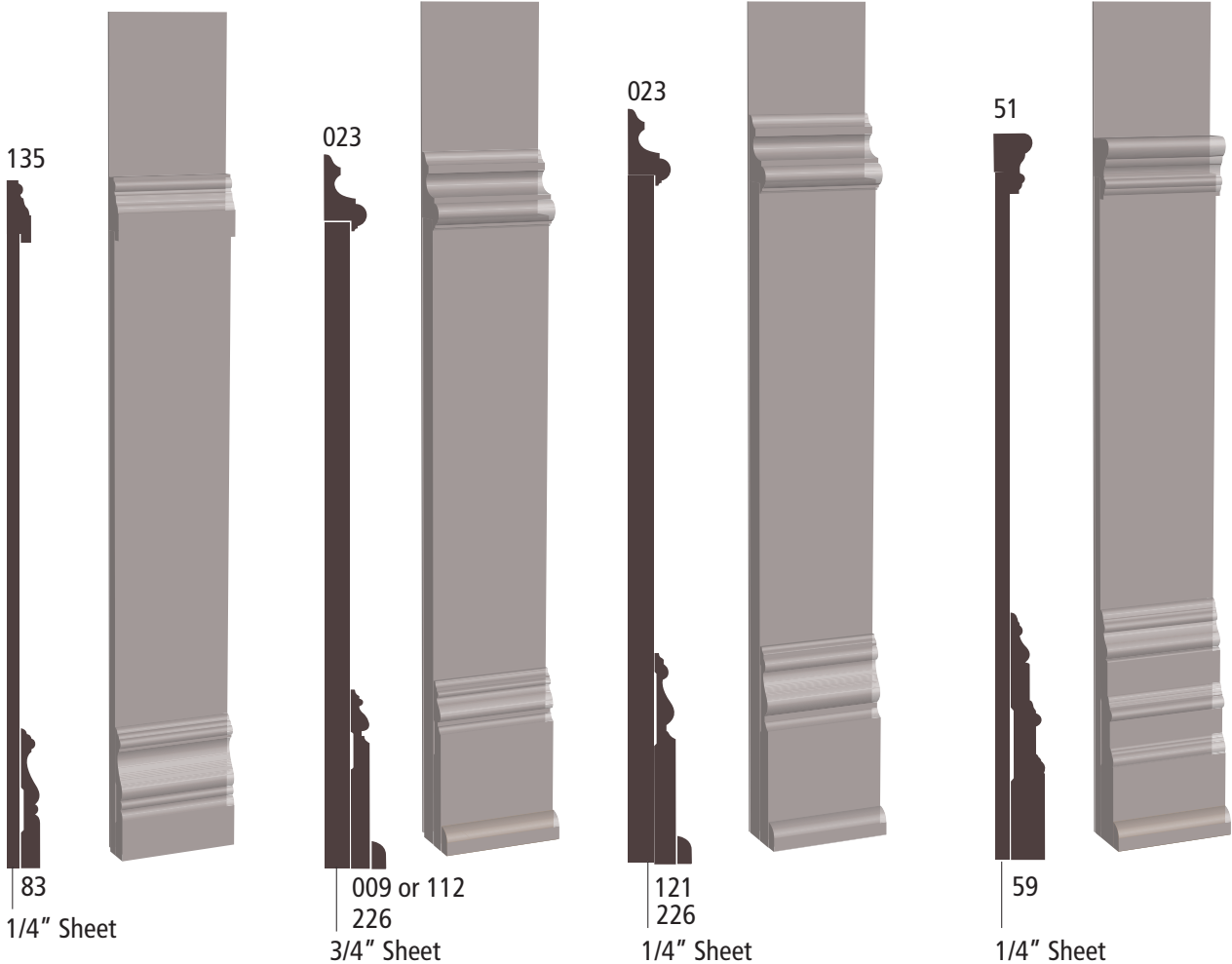
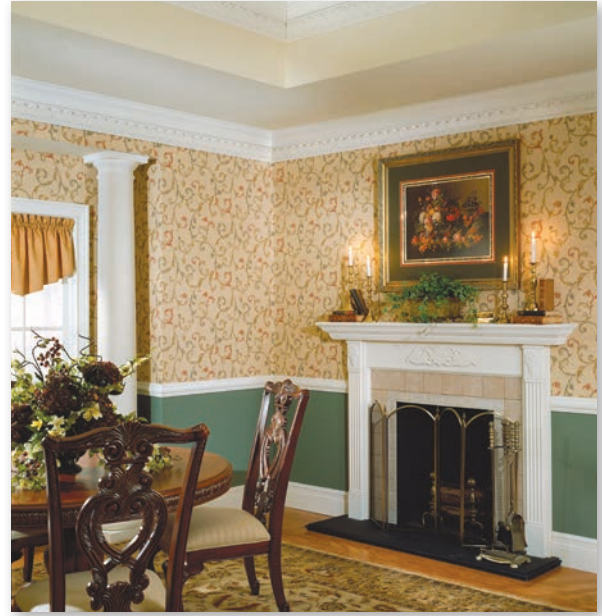

Wainscoting and Picture Mould

The chair rail, a common feature in dining rooms of more prosperous colonial-classic homes, is more widely used in parlors and other public rooms. A variation of the chair rail known as a Plate Rail, often with raised panel wainscoting, was also very common. Interior decorators refer to this look as the "three part wall", with each section receiving a different treatment such wood, fabric, or plaster.



51



115

134 Panel

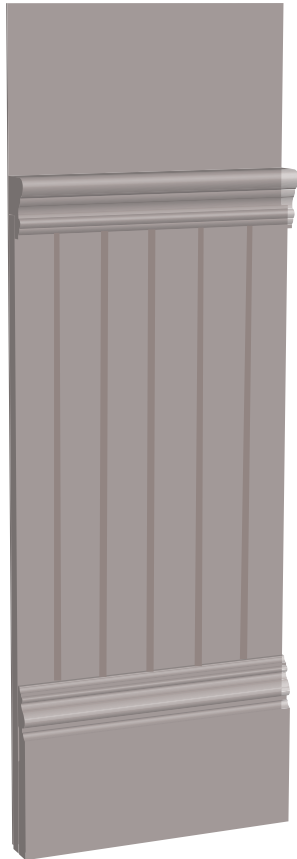

390



83

1/4" Sheet

384



Craftsman and Mission Inspired Styles





Influences of the Arts & Crafts Movement

From the excesses of the Victorian era, there came a new movement of artists and architects emphasizing the simplicity of form, natural materials, and individual craftsmanship over industrialization. This period saw a move away from the detail and ornamentation of the Victorian and previous eras, to simpler, more rectangular forms.

In America this movement was embodied most notably in the Craftsman and Bungalow style homes of the early 1900's. Notable architects and designers of the day such as Gustav Stickley and the Green brothers embraced the style in many projects. Other notable architects such as Frank Lloyd Wright, George Elmslie & William Purcell, implemented the look in finer home designs in what would become known as the Prairie Style. The movement shared much with the architecture of the Spanish missions found in the western United States, and these simple forms and natural woods influenced home design for many decades.

The Craftsman and Arts & Crafts style historically was implemented in natural wood, however paint treatments with todays decor trends are equally impressive.

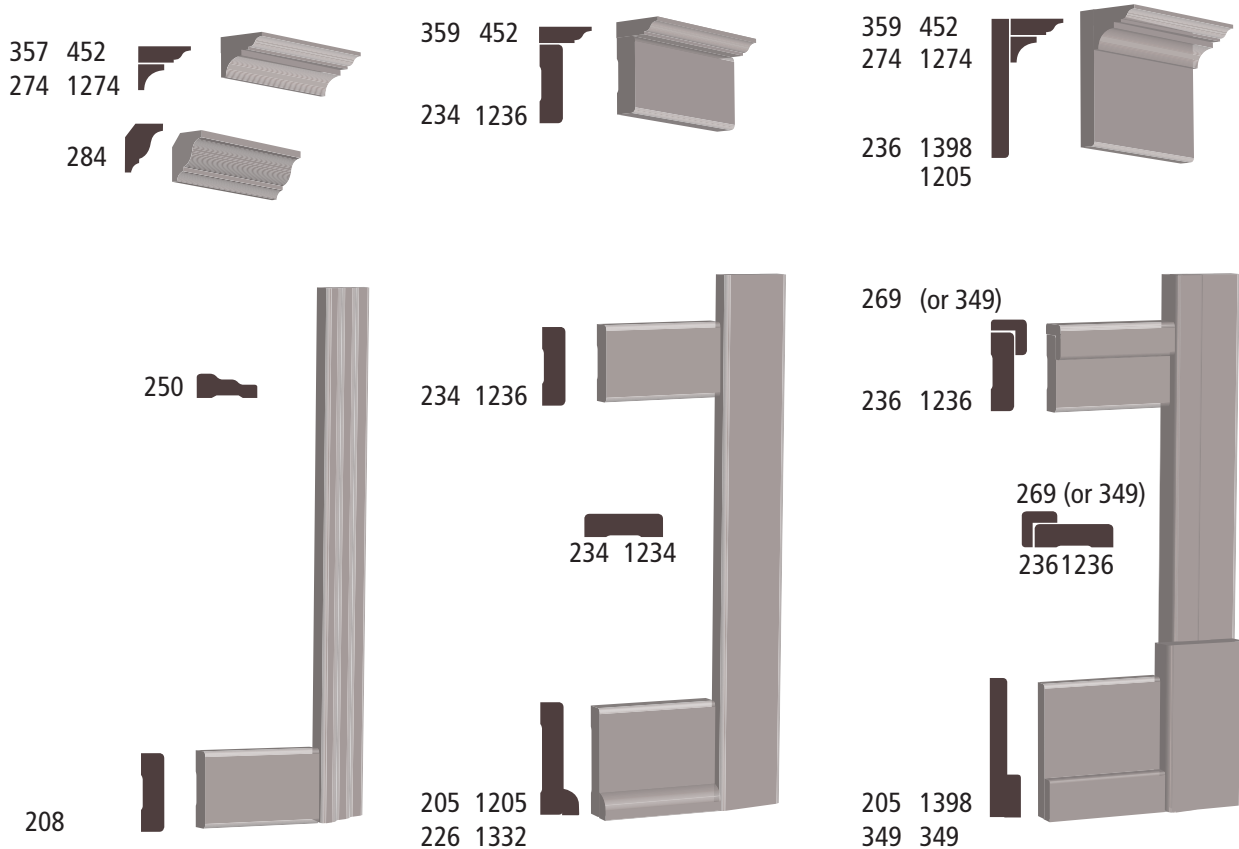

Moulding numbers are based on Kelleher part numbers used in different species and finishes of wood. Ask your retailer about specific patterns.

Craftsman & Mission Styling Cues:

Important styling cues of this era are rectangular shapes of beautifully grained or painted wood, with rounded or eased edges... and always cut and installed using precise carpentry! Additional details or embellishments when desired usually consist of some additional edging details, a cove, or a classically formed ogee used in a door pediment or crown. Architects, particularly in finer homes, chose to soften the impact of such a stark design on their clients.

When remodeling a home in this style, paint finishes are often more practical and allow the use of MDF and Primed Pine mouldings. Natural wood mouldings in species such as Alder, Poplar, Douglas Fir or Oak are also attractive options.

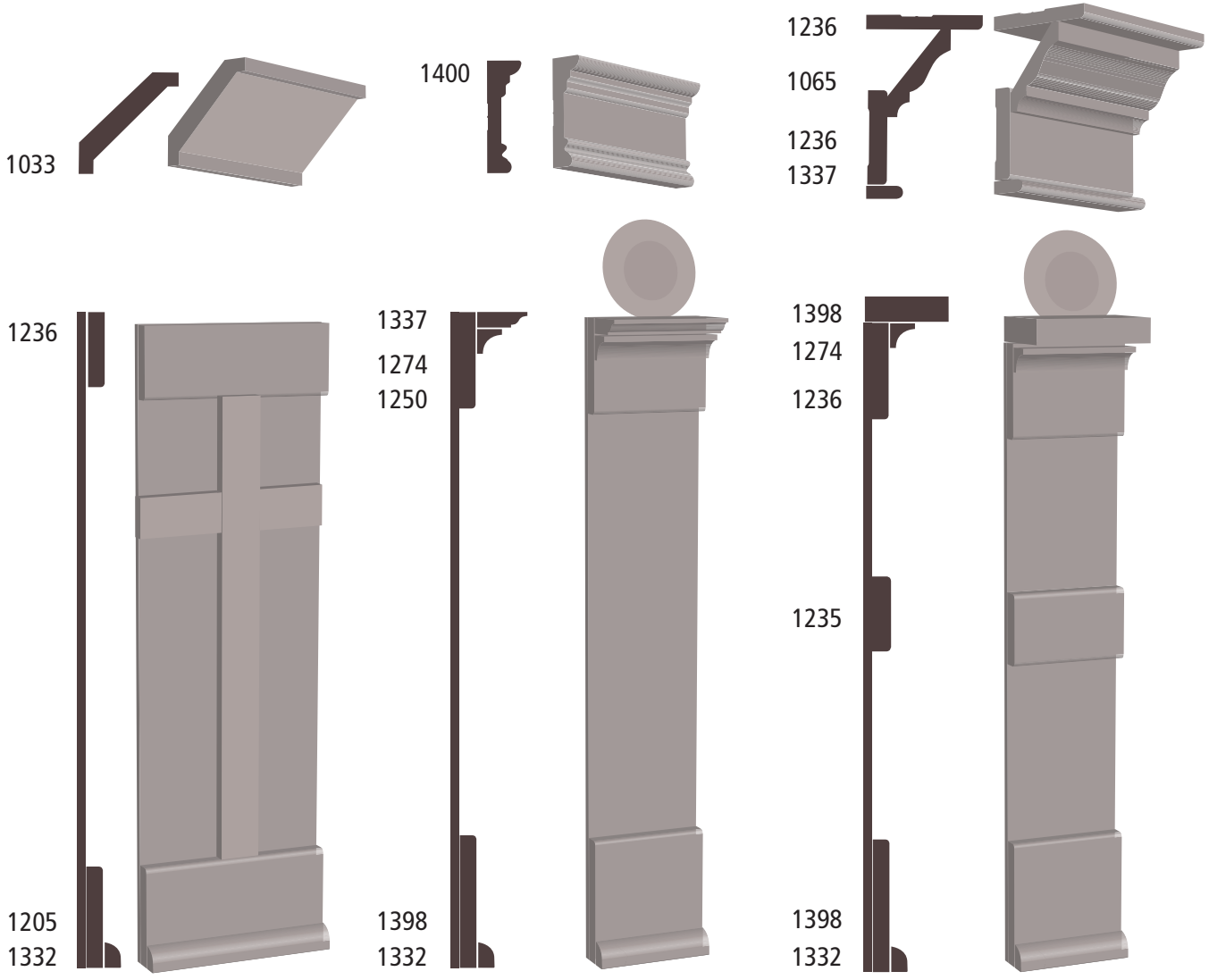

Craftsman Door and Window Details

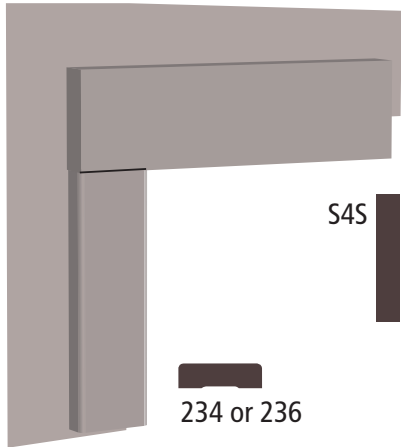

S4S
234 or 236

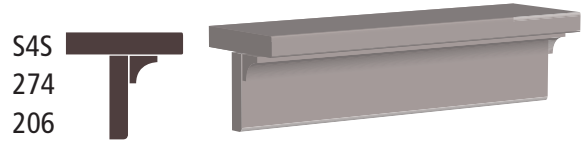

S4S
274
206

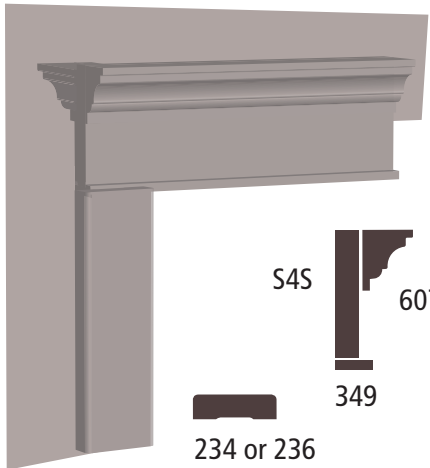

S4S
607
349
234 or 236

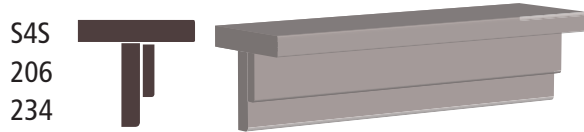

S4S
206
234

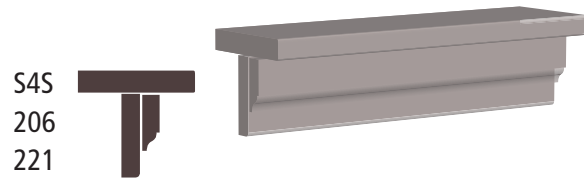

S4S
206
221

P-876PPR
P-5435PPR
P-895PR



P-847PPR



269 (or 349)
236 1236

205 1398
349 349

Contemporary and Blended Styles



This blend of painted Craftsman style mouldings, combined with natural wood accents and doors, makes for a very dramatic interior.



When installing or upgrading windows, consider upgrading the window casing treatments and other mouldings in the room. Natural wood dramatically changes the feeling of a recently built home or Condo.



The **Craftsman** and **Prairie** styles, **Colonial Revival**, and other styles lasted well into the 20th century, and were adapted to suit the many styles of homes being built. Homes in the Western and Southwestern United States continued to be influenced by the architecture of Spanish Missions. Mouldings added a finished look to home designs that typically featured tiled floors and rustic wall treatments. Homes often maintained a link to the grandeur of their European roots by using one or more decorative crowns or casings.

Builders during the post-war housing boom, however, generally paid less attention to moulding and trim than in the past. Those that did often used scaled down versions of traditional patterns or opted for variations of the **Craftsman** style. Many of these homes however are a wonderful canvas to express one's own style and design ideas. The **Ranch** and other homes of suburban America often bring new needs for built-in entertainment cabinetry, casings for expansive windows, and kitchens which are increasingly part of today's open floor plans.

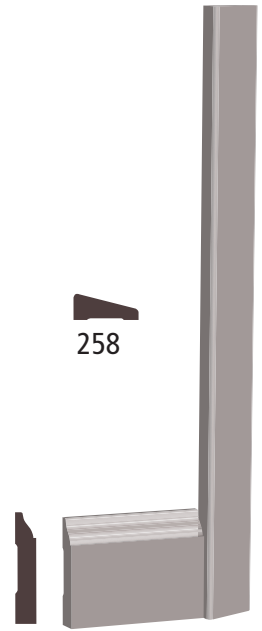
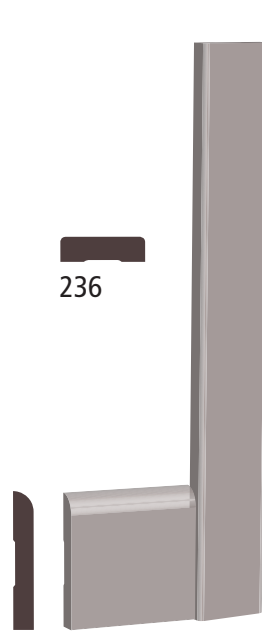
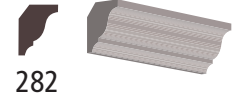
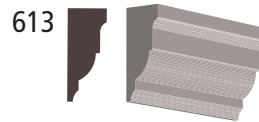

207 or 209

221

Moulding numbers are based on Kelleher part numbers that may be available in several species of wood. Ask your retailer about specific patterns.

Revival and Contemporary Styles

As the use of moulding evolved over time, there have periodically been movements by designers and architects to return to the simple classic forms based on neoclassical Greek and Roman architecture. Furthermore, many of the classic forms remained in use through many architectural periods, just as many styles are used in homes today. Improved manufacturing allowed mills to combine several previously built-up mouldings into a single profile, and make them available to a wider market of consumers. Hence the Colonial Revival style evolved based on neoclassical designs. Moulding profiles were simpler or scaled down in size to suit the growing numbers of middle class consumers and smaller rooms.

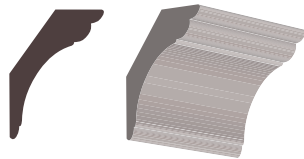

611

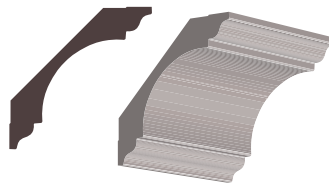

44A

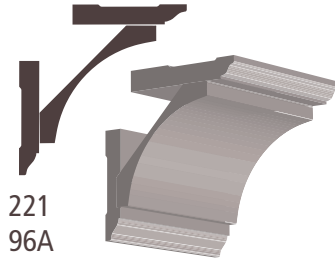

221
96A
221

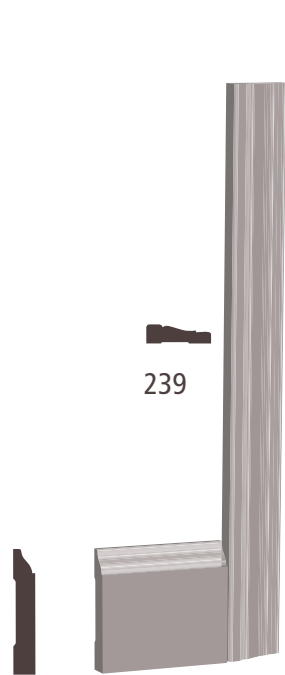

223

239

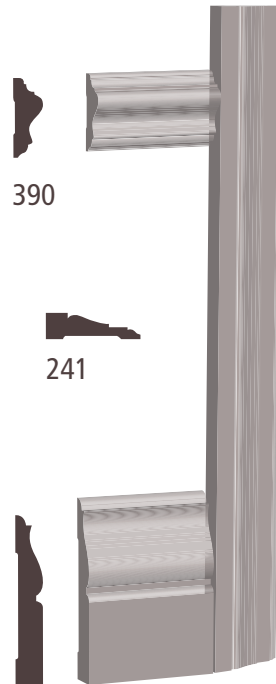

390

241

016

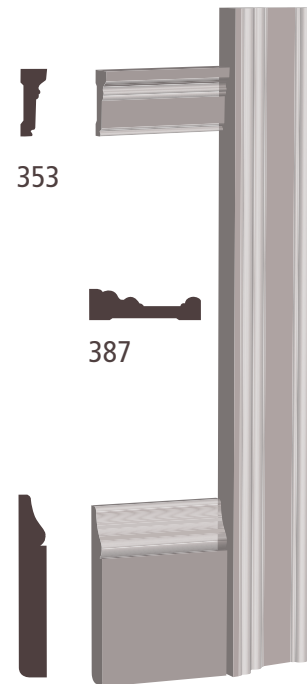

353

387

215

Try taking inspiration from the many historical designs presented in this guide. If your ceilings and entry ways are not high enough to use elaborate build-ups, consider some of the smaller graceful shapes of the Colonial or Victorian patterns. If your home has simple round edge trim, consider adding a variety of caps and back bands to enhance the existing installation.

Try combining moulding and trim with dramatic paint schemes. Add picture rails or chair rails to your room and try contrasting or complementary colors above and below the horizontal lines.

Upgrading to natural wood mouldings such as Poplar, Alder and Douglas Fir adds warmth and character to any room. The lighter tones and subtle grains complement even the most refined interior design styles. Solid Pine and Oak mouldings can also be stained for a variety of pleasing finishes.

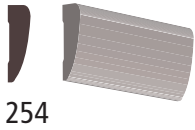

254

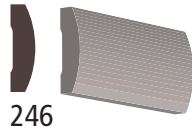

246



212

232

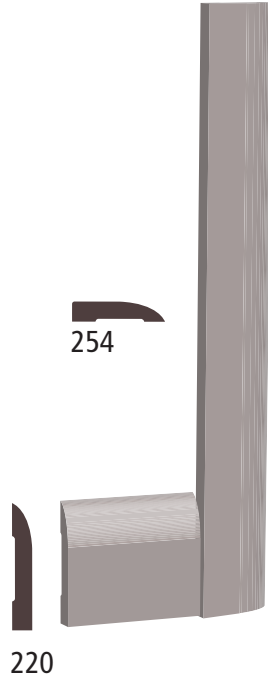

220

254



Special Moulding Applications

There are many creative and functional applications for mouldings and accessories in kitchens and bathrooms, and special areas like a mudroom or entry area present many opportunities for a unique decorative look. A splash of traditional moulding in a decidedly modern decor can make it more dynamic.



This mudroom is a blend of fine carpentry and functional design, and protects the wall from damage and moisture.



Wainscoting is attractive in traditional bathrooms and protects the walls from moisture.

Consider moulding and trim options for cabinets when planning a kitchen remodeling project.





This built-in window seating unit is anchored into the room through its window casings.



Raised Coffered ceilings with moulding treatments add drama to a room.

Usage Ideas



Even a room with contemporary furnishings is complemented by classic mouldings.



Column treatments and beams created from room mouldings extend the look and define spaces in an open plan.

Usage Ideas



The contrast of mouldings in this very contemporary decor combined with the flooring treatment adds depth to the room.



This traditional room decor uses a contemporary paint treatment to highlight the moulding and add interest.

Usage Ideas



Craftsman style mouldings are less ornate, while still making an elegant statement. This style is both comfortable and easy to maintain. The perfect choice for a busy family home.

image courtesy curranonline.com



This blend of contemporary room decor against a backdrop of traditional window casings and divided lite windows complement each other.

Usage Ideas



An elegant yet rustic feel is established in this interior by combining vertically installed "Nickel Gap" profiles (MDF section) and Colonial style mouldings.

Design Resources

We invite readers to consult any of the books and websites listed below for help in designing and installing their moulding and trim applications. Most books are available from www.amazon.com or at the publishers website listed below. Also be sure to check out the popular design / social media sites www.houzz.com and www.pinterest.com, and search "Moulding."



Fox Chapel Publishing publishes two fine books with many trim ideas Ultimate Guide Trimwork & 1001 Ideas for Trimwork, available from www.amazon.com



Crown Moulding & Trim is an excellent installation guide and works well with True Angle™ moulding measurement devices. Available from Kelleher Retail Outlets.



Dover Publications publishes a variety of books documenting historical moulding and millwork applications. www.doverpublications.com



Elements of Style: An Encyclopedia of Domestic Architectural Detail. ISBN 1-55407-079-1 Firefly Books, www.fireflybooks.com.



Abrams Guide to Period Styles for Interiors ISBN 0-8109-5914-3 www.abramsbooks.com



Creating a New Old House: Yesterday's Character for Today's Home ISBN 1-5615-8615-3

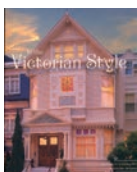

In the Victorian Style San Francisco Victorian Homes ISBN 0-8118-5360-8



In the Arts & Crafts Style A guide to an Enduring Style ISBN 0-8118-0505-7

Web links:

Bungalow Home Information www.ambungalow.com

Architectural and Period Styles Explained www.architecturestyles.org

Houzz:  houzz

See what cutting edge designers and contractors are doing at www.Houzz.com (Search 'Moulding')

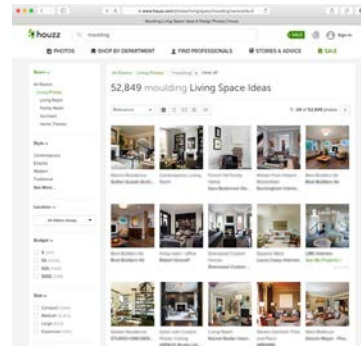

Pinterest: 

See what homeowners, DIYers, contractors and suppliers are doing at www.Pinterest.com (Search 'Moulding')

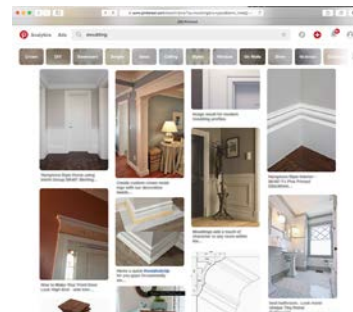

www.kelleher.com

Visit our website for more information about our products, how-to information, and to order a catalog.



MEDIUM DENSITY FIBERBOARD

**Floor, Ceiling, Wall, Window
and Door, Utility Moulding**

MDF Moulding

About MDF



MDF mouldings are manufactured from medium density fiberboard. These mouldings are used in paint grade interior applications. They are finer and more dense than particle board materials that many people are more familiar with. Among the many reasons to use MDF are:

- Most of the popular moulding profiles are available in MDF.
- The manufacturing process insures a uniform consistency without the imperfections that may exist in other paint grade products.
- MDF does not warp or split and does not expand and contract like natural wood species.
- MDF has a hard surface that will not damage easily and that will not show raised grain.
- MDF mouldings are primed and there is very little surface preparation required for finishing.
- MDF mouldings are less expensive than other wood paint grade mouldings. This is especially true in larger architectural profiles.

MDF should not be used where moisture is common. In high traffic areas it is best to avoid mouldings with sharp angles as MDF is slightly more prone to chip than wood mouldings. MDF mouldings may be used alongside wood mouldings in some cases where a certain look is desired.





2-1/4" to 3-1/2" Base



R.E. Base

3/8 x 2-1/4

MDF212A PRIMED MDF

Also available in:

3-1/4, 3-1/2, 4-1/2, 5-1/2, 7-1/4

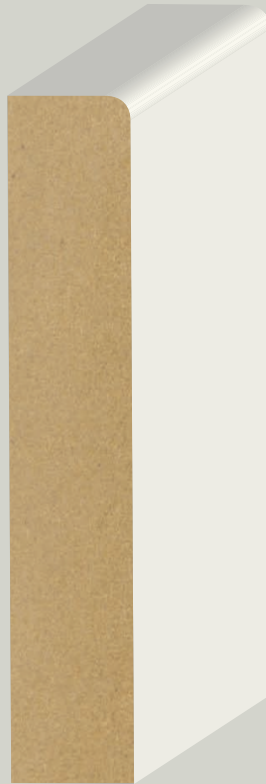

R.E. Base

1/2 x 3-1/4

MDF210A PRIMED MDF

1/2 x 3-1/2

MDF830A PRIMED MDF

Also available in:

2-1/4, 4-1/2, 5-1/2, 7-1/4



711 Base

7/16 x 2-1/2

MDF409A PRIMED MDF

Also available in:

3-1/2



Wainscot Base

9/16 x 3-1/4

MDF137A PRIMED MDF

3-1/4" to 3-1/2" Base



Sierra Base

9/16 x 3-1/4

MDF216A PRIMED MDF

Also available in:
5-1/4, 7-1/4



711 Base

7/16 x 3-1/2

MDF410A PRIMED MDF

Also available in:
2-1/2



Santa Fe Base

9/16 x 3-7/16

MDF203A PRIMED MDF

Also available in:
4-1/2, 5-7/16, 9-1/4



Coronado Base

9/16 x 3-1/4

MDF221A PRIMED MDF

1/2 x 3-1/4

MDF221AS PRIMED MDF

Also available in:
4-1/4, 5-1/4, 7-1/4

3-1/2" to 4-1/8" Base

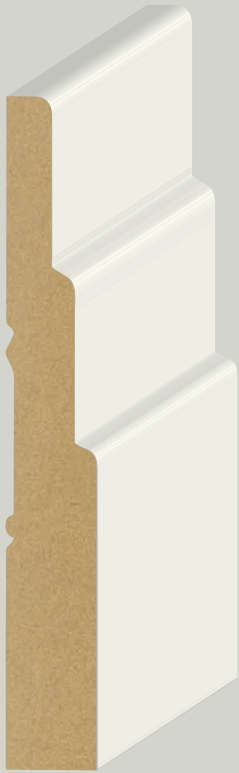

Three Step Base

1/2 x 3-1/2

MDF558A PRIMED MDF

Also available in:
4-1/8

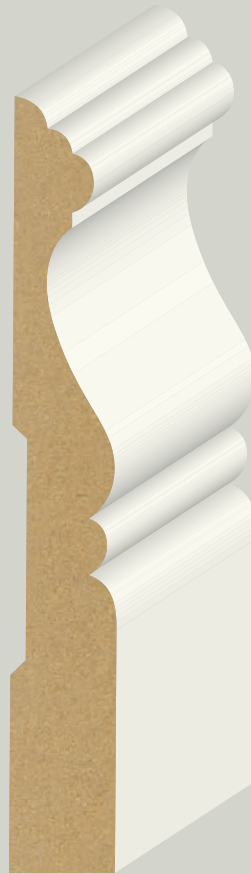

Victorian Base

9/16 x 4

MDF83A PRIMED MDF



Victorian Base

9/16 x 3-7/8

MDF20A PRIMED MDF

Also available in:
5", 5-1/4, 7-1/4

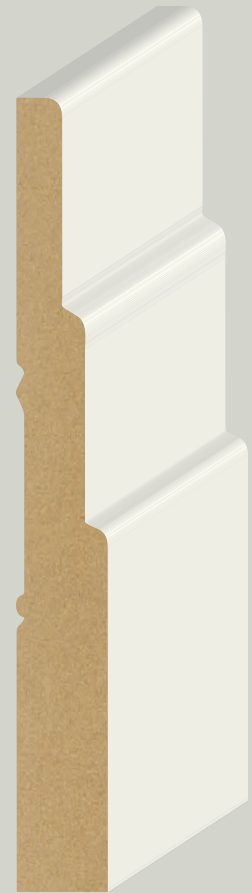

Three Step Base

1/2 x 4-1/8

MDF581A PRIMED MDF

Also available in:
3-1/2

4-1/4" to 4-1/2" Base



Solana Base

5/8 x 4-1/4

MDF416A PRIMED MDF



Coronado Base

9/16 x 4-1/4

MDF222A PRIMED MDF

Also available in:
3-1/4, 5-1/4, 7-1/4



Del Mar Base

9/16 x 4-1/2

MDF84A PRIMED MDF

4-1/2" to 5-1/4" Base

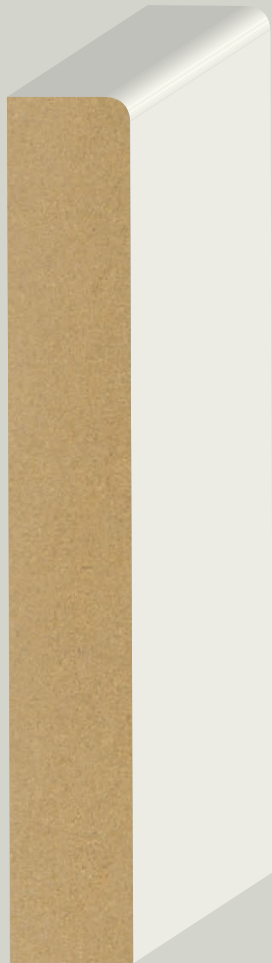

R.E. Base

1/2 x 4-1/2

MDF831A PRIMED MDF

Also available in:

2-1/4, 3-1/4, 3-1/2, 5-1/2, 7-1/4



Santa Fe Base

9/16 x 4-1/2

MDF233A PRIMED MDF

Also available in:

3-7/16, 5-7/16, 9-1/4



Victorian Base

9/16 x 5-1/4

MDF029A PRIMED MDF

9/16 x 5

MDF22A PRIMED MDF

Also available in:

3-7/8, 7-1/4

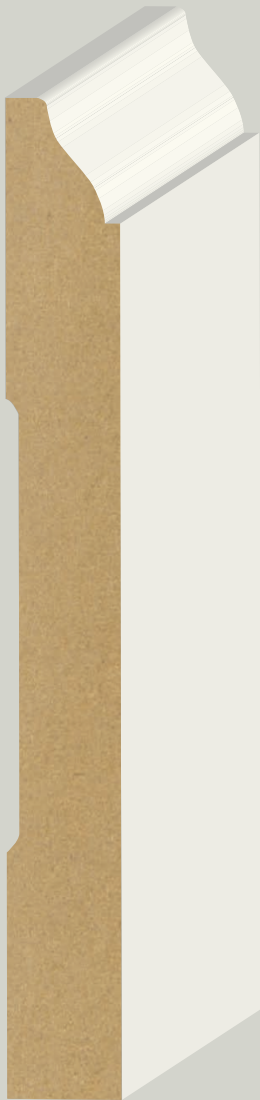

Coronado Base

9/16 x 5-1/4

MDF223A PRIMED MDF

1/2 x 5-1/4

MDF223AS PRIMED MDF

Also available in:

3-1/4, 4-1/4, 7-1/4



Harris Base

9/16 x 5-1/4

MDF74A PRIMED MDF



Georgian Base

9/16 x 5-1/4

MDF114A PRIMED MDF

5-1/4" Base

MEDIUM DENSITY FIBERBOARD

40

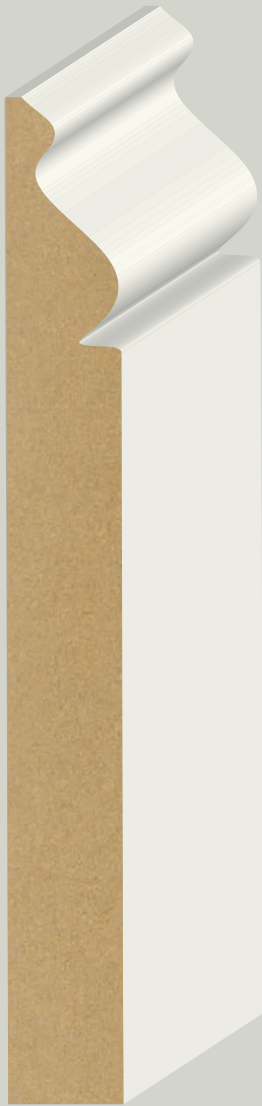

Vintage Base

9/16 x 5-1/4

MDF26A PRIMED MDF

Also available in:
6-1/8



Monterey Base

9/16 x 5-1/4

MDF120A PRIMED MDF

Also available in:
7-1/4, 9-1/4



Sierra Base

9/16 x 5-1/4

MDF217A PRIMED MDF

1/2 x 5-1/4
MDF217AS PRIMED MDF

Also available in:
3-1/4, 7-1/4

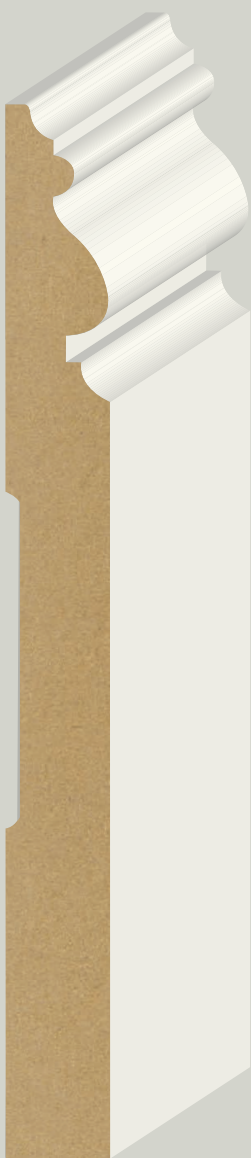

Santa Fe Base

9/16 x 5-7/16

MDF112A PRIMED MDF

Also available in:

3-7/16, 4-1/2, 9-1/4

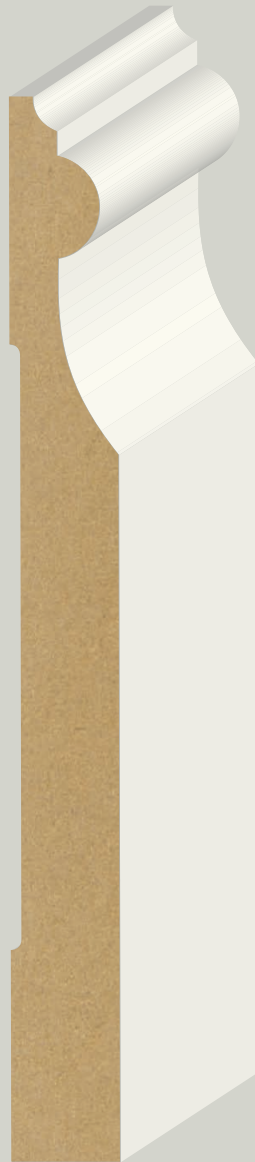

Beaded Base

9/16 x 5-7/16

MDF004A PRIMED MDF

Also available in:

7-1/4



5-1/2" to 5-3/4" Base



Bullnose Base

9/16 x 5-1/2

MDF907A PRIMED MDF

11/16 x 5-1/2

MDF207A PRIMED MDF

Also available in:

7-1/4

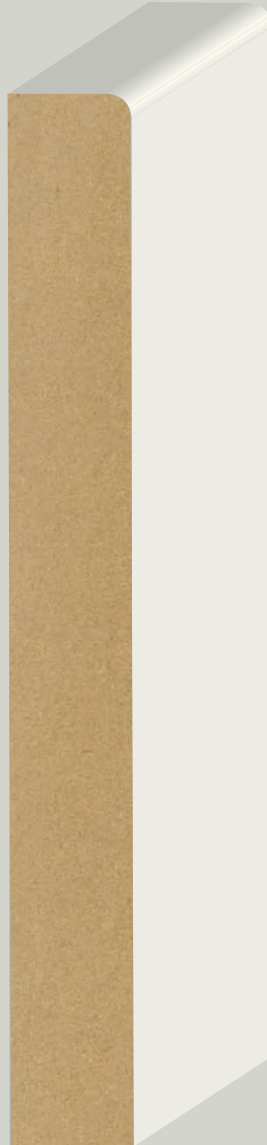

R.E. Base

1/2 x 5-1/2

MDF206A PRIMED MDF

Also available in:

2-1/4, 3-1/4, 3-1/2, 4-1/2, 7-1/4



Santa Clara Base

3/4 x 5-3/4

MDF129A PRIMED MDF

6" to 6-1/2" Base

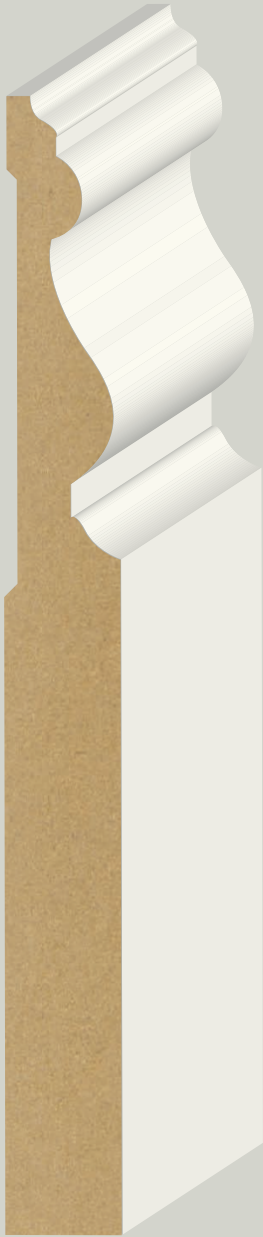

Imperial Base

5/8 x 6

MDF24A PRIMED MDF

Also available in:

8-1/4

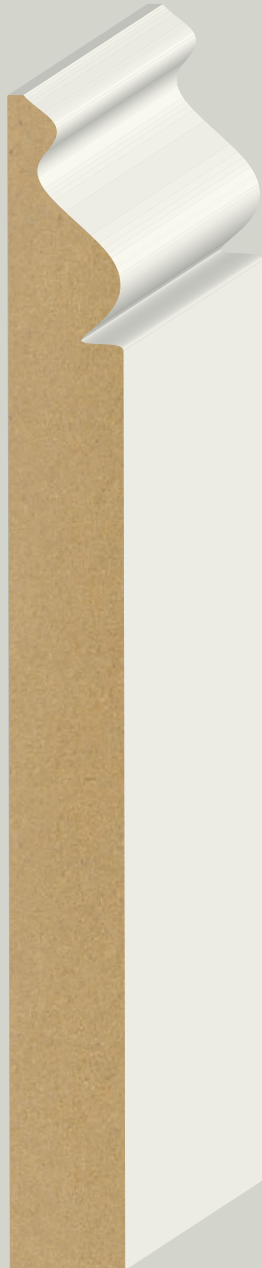

Vintage Base

5/8 x 6-1/8

MDF28A PRIMED MDF

Also available in:

5-1/4



Savannah Base

9/16 x 6-1/2

MDF30A PRIMED MDF

6-1/2" to 7-1/4" Base



Plinth Base

3/4 x 6-1/2
MDF299A PRIMED MDF



Sierra Base

9/16 x 7-1/4
MDF116A PRIMED MDF

Also available in:
3-1/4, 5-1/4

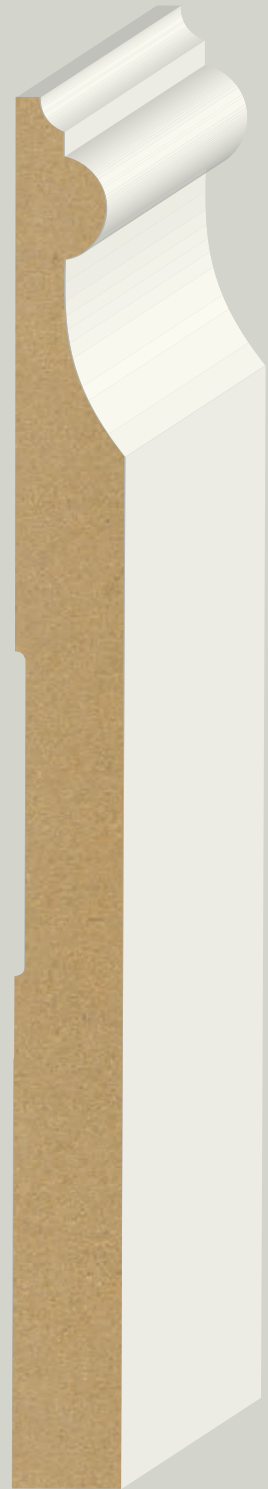

Beaded Base

5/8 x 7-1/4
MDF044A PRIMED MDF

Also available in:
5-7/16



Malibu Base

5/8 x 7-1/4

MDF88A PRIMED MDF

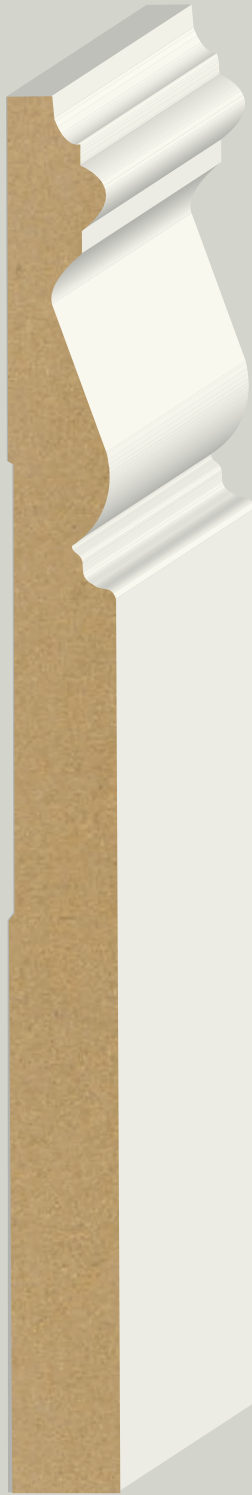

Monterey Base

9/16 x 7-1/4

MDF121A PRIMED MDF

*Also available in:
5-1/4, 9-1/4*



Victorian Base

9/16 x 7-1/4

MDF031A PRIMED MDF

*Also available in:
3-7/8, 5", 5-1/4*

7-1/4" Base

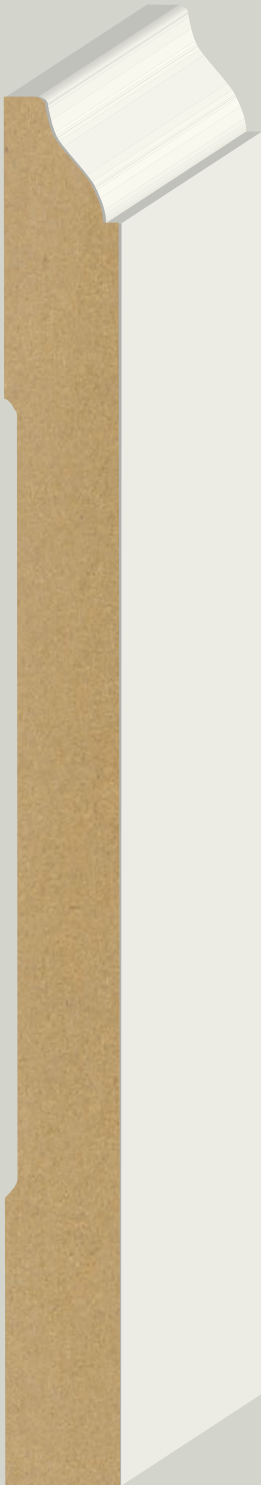

Coronado Base

9/16 x 7-1/4
MDF227A PRIMED MDF

Also available in:
3-1/4, 4-1/4, 5-1/4



Bullnose Base

9/16 x 7-1/4
MDF909A PRIMED MDF

Also available in:
5-1/2

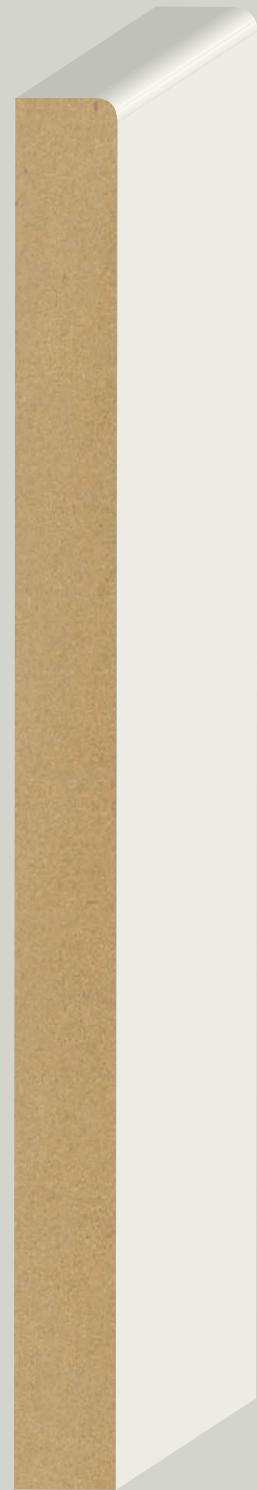

R. E. Base

1/2 x 7-1/4
MDF834A PRIMED MDF

Also available in:
2-1/4, 3-1/4, 3-1/2, 4-1/2, 5-1/2

8-1/4" to 9-1/4" Base

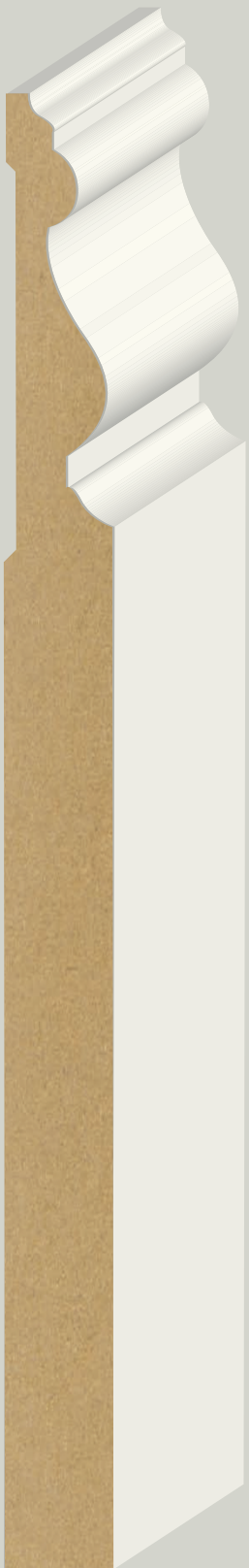

Imperial Base

5/8 x 8-1/4

MDF25A PRIMED MDF

Also available in:

6"



Monterey Base

9/16 x 9-1/4

MDF123A PRIMED MDF

Also available in:

5-1/4, 7-1/4

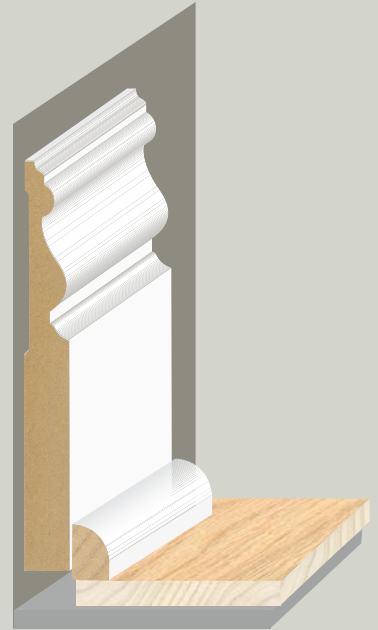

Installation Tip:

Use a Base Shoe moulding to cover the gap between baseboard mouldings and finished flooring surfaces. They add a finished look to taller baseboard mouldings.

9-1/4" Base



Santa Fe Base

9/16 x 9-1/4

MDF115A PRIMED MDF

Also available in:

3-7/16, 4-1/2, 5-7/16



Legacy Base

1 x 9-1/4

MDF59A PRIMED MDF



1-9/16" to 2-1/4" Casing

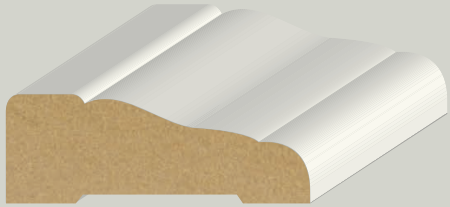

Moulded Casing

5/8 x 1-5/8

MDF238A PRIMED MDF ⚙️

Also available in:
3-1/4



R.E. (Round Edge) Casing

9/16 x 2-1/4

MDF234A PRIMED MDF ⚙️

Also available in:
3-1/4, 4-1/2



Bevel Casing

9/16 x 1-9/16

MDF256A PRIMED MDF ⚙️

MDF256MWS WATER PRIMED MDF (MITRED WRAPPED SET)

Also available in:
2-1/4



Colonial/356 Casing

5/8 x 2-1/4

MDF239A PRIMED MDF ⚙️

MDF239AP (102" Pairs) PRIMED MDF

11/16 x 2-1/4

MDF239MWS WATER PRIMED MDF (MITRED WRAPPED SET)



Bevel Casing

9/16 x 2-1/4

MDF258A PRIMED MDF ⚙️

Also available in:
1-9/16



Flute & Reed Casing

11/16 x 2-1/4

MDF027A PRIMED MDF

Also available in:
3-3/8, 4-1/4

2-1/4" to 2-1/2" Casing

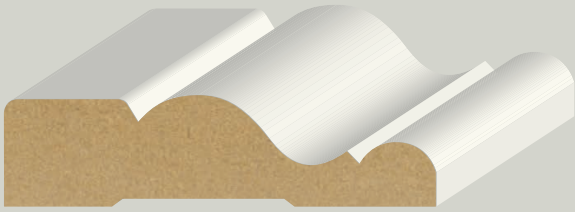

Carmel Casing

5/8 x 2-1/4

MDF142A PRIMED MDF

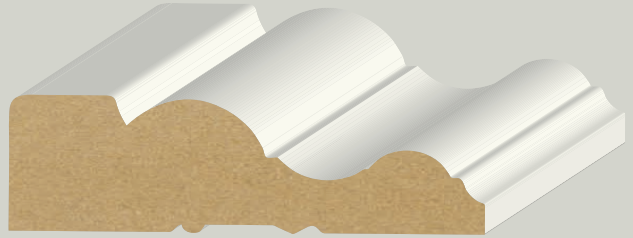

Malibu Casing

11/16 x 2-1/2

MDF551A PRIMED MDF



Carolina Casing

11/16 x 2-7/16

MDF013A PRIMED MDF

Also available in:

3-1/4

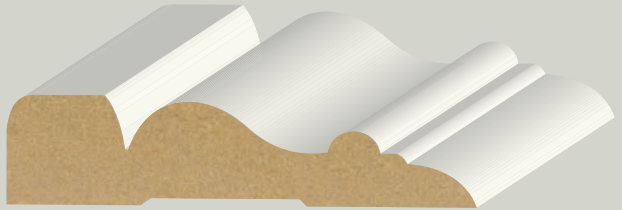

Victorian/Bay Shore Casing

5/8 x 2-1/2

MDF32A PRIMED MDF

Also available in:

3"



Santa Fe Casing

11/16 x 2-7/16

MDF008A PRIMED MDF

Also available in:

3-7/16

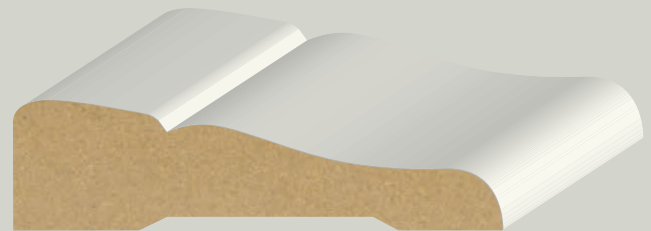

711 Casing

5/8 x 2-1/2

MDF424A PRIMED MDF ⚙

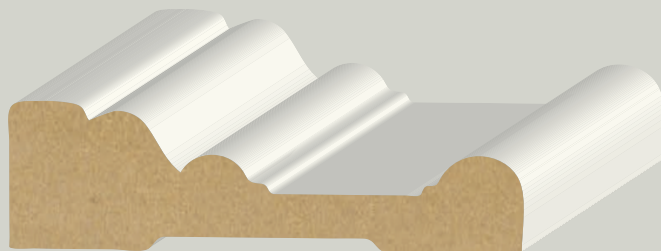

Howe Casing

3/4 x 2-7/16

MDF367A PRIMED MDF

Also available in:

3-1/4, 4-1/2

⚙ Available in Cut to Length)

2-1/2" to 2-5/8" Casing

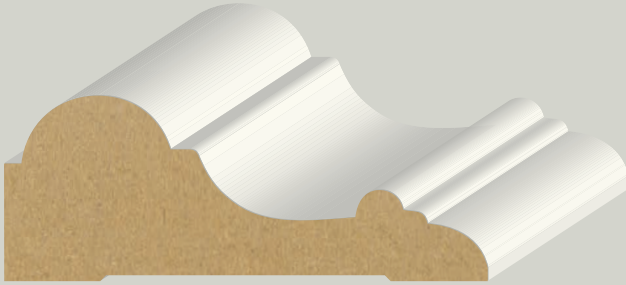

Lancaster Casing

1 x 2-1/2

MDF35A PRIMED MDF

Also available in:
3-3/16

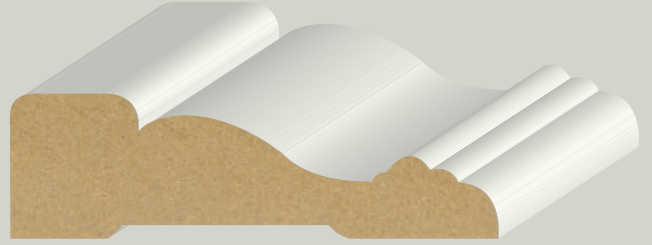

Victorian Casing

11/16 x 2-1/2

MDF262A PRIMED MDF

MDF262AP102 (102" Pairs) PRIMED MDF

Also available in:
3-1/4

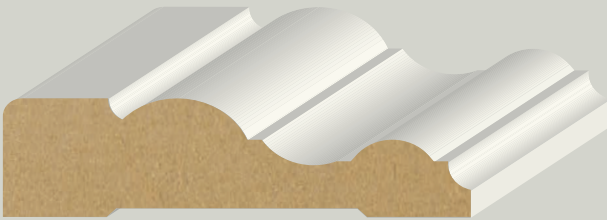

Mackenzie Casing

5/8 x 2-1/2

MDF144A PRIMED MDF

Also available in:
3-1/2

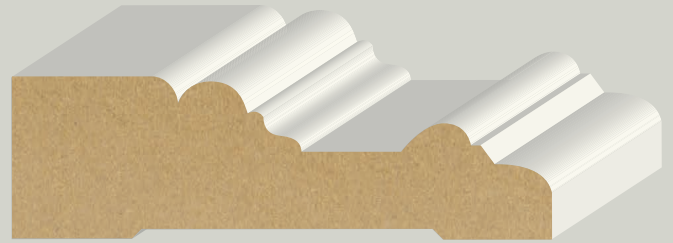

Belmont Casing

3/4 x 2-5/8

MDF71A PRIMED MDF

Also available in:
3-1/2



Riviera Casing

5/8 x 2-1/2

MDF385A PRIMED MDF 

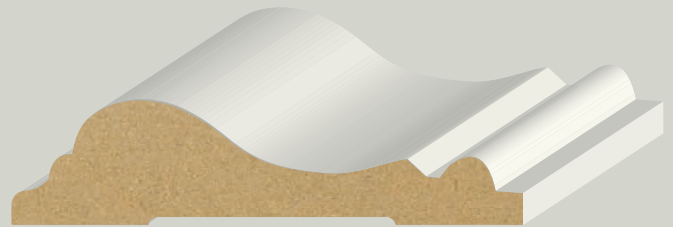

Coronado Casing

11/16 x 2-5/8

MDF382A PRIMED MDF

3" to 3-1/4" Casing

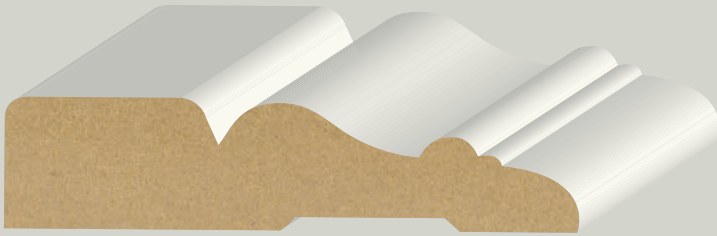

Victorian/Bayshore Casing

5/8 x 3

MDF028A PRIMED MDF

Also available in:
2-1/2

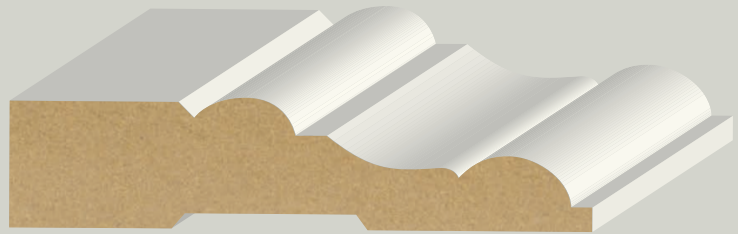

Del Mar Casing

5/8 x 3

MDF72A PRIMED MDF



Lancaster Casing

1-3/16 x 3-3/16

MDF36A PRIMED MDF

Also available in:
2-1/2



Carolina Casing

11/16 x 3-1/4

MDF40A PRIMED MDF

Also available in:
2-7/16

3-1/4" Casing

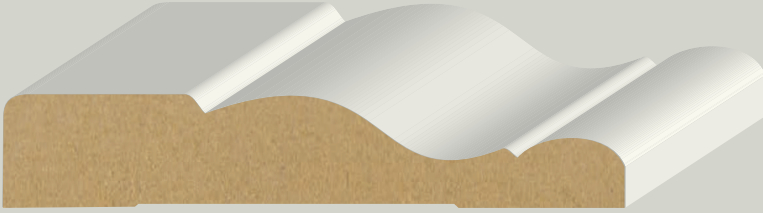

Montana Casing

5/8 x 3-1/4

MDF66A PRIMED MDF



Monterey Casing

11/16 x 3-1/4

MDF124A PRIMED MDF

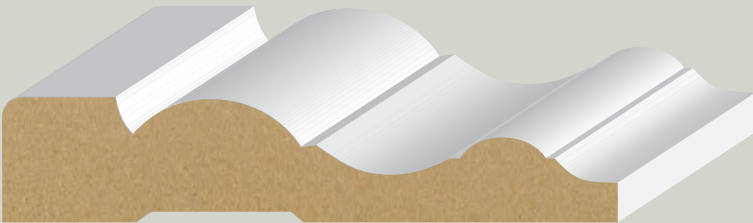

Mission Casing

3/4 x 3-1/4

MDF68A PRIMED MDF



R.E. Casing

9/16 x 3-1/4

MDF236A PRIMED MDF

Also available in:

2-1/4, 4-1/2

3-1/4" to 3-3/8" Casing

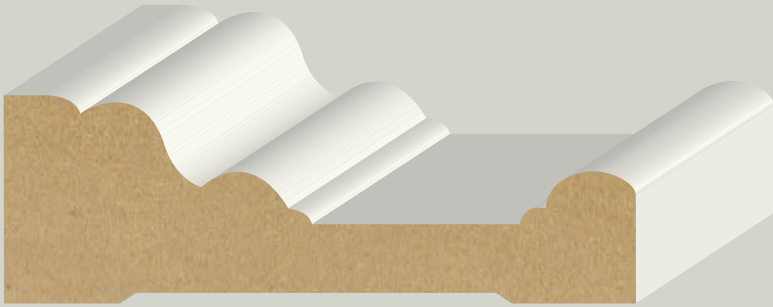

Howe Casing

1-1/16 x 3-1/4

MDF387A PRIMED MDF

Also available in:

2-7/16, 4-1/2



Moulded Casing

9/16 x 3-1/4

MDF242A PRIMED MDF

Also available in:

1-5/8

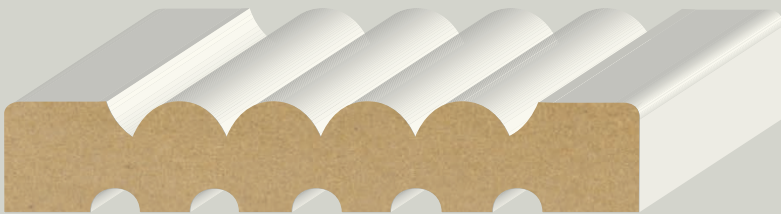

Flute & Reed Casing

5/8 x 3-3/8

MDF386A PRIMED MDF

Also available in:

2-1/4, 4-1/4

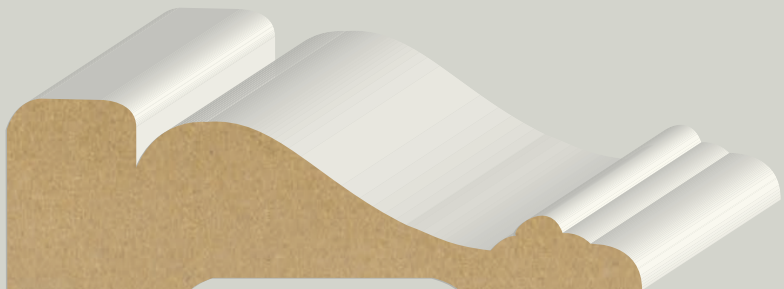

49er Casing

1 x 3-1/4

MDF380A PRIMED MDF

Also available in:

2-1/2

3-3/8" to 3-9/16" Casing

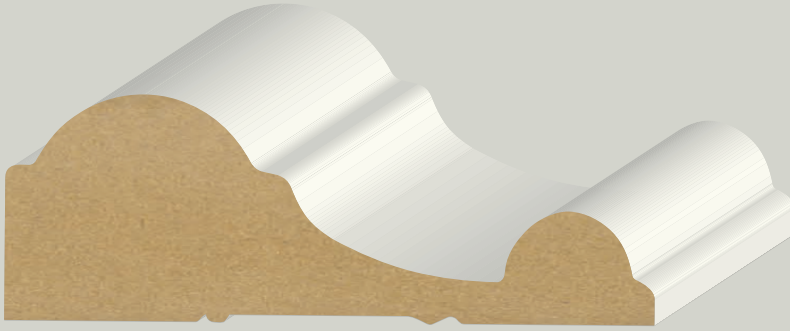

Venice Casing

1-3/16 x 3-3/8

MDF555A PRIMED MDF

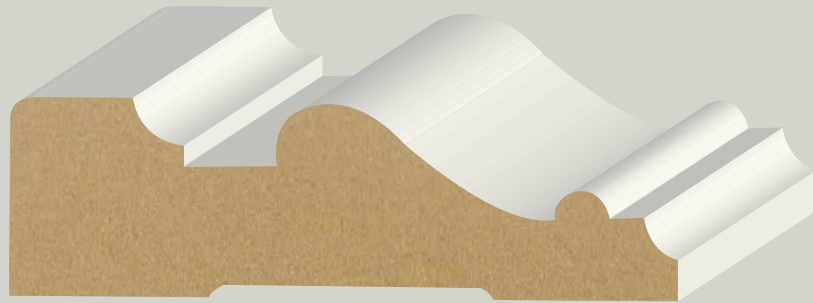

Santa Fe Casing

1-1/16 x 3-7/16

MDF393A PRIMED MDF

Also available in:
2-7/16



Georgian Casing

11/16 x 3-9/16

MDF122A PRIMED MDF

3-1/2" Casing



Shasta Casing

1 1/16 x 3-1/2

MDF391A PRIMED MDF

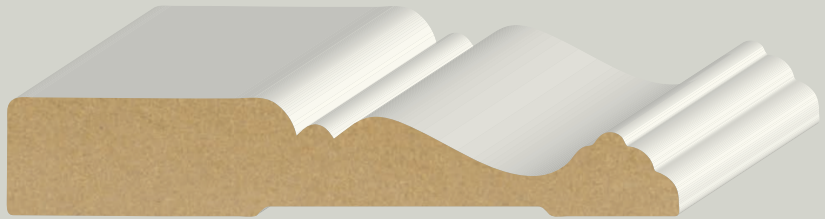

Victorian Casing

3/4 x 3-1/2

MDF395A PRIMED MDF

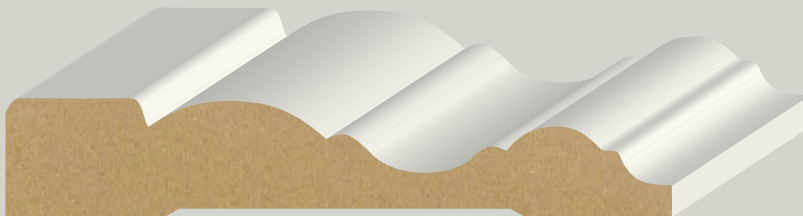

Mackenzie Casing

5/8 x 3-1/2

MDF145A PRIMED MDF

Also available in:

2-1/2



Belmont Casing

1" x 3-1/2

MDF73A PRIMED MDF

Also available in:

2-5/8

4-1/4" to 4-1/2" Casing



Belvedere Casing

1-3/16 x 4-1/2
MDF69A PRIMED MDF



Flute & Reed Casing

11/16 x 4-1/4
MDF389A PRIMED MDF

Also available in:
2-1/4, 3-3/8



4-1/2" Casing

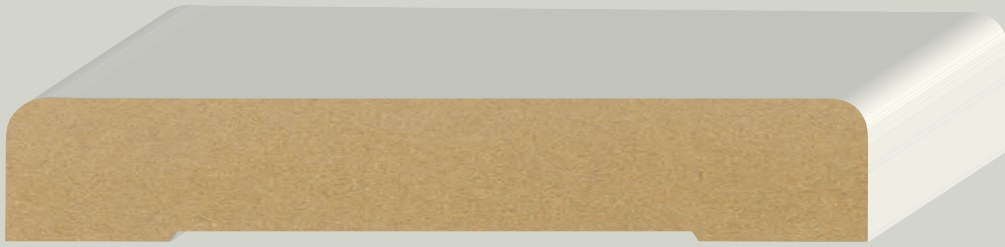

R.E. Casing

3/4 x 4-1/2

MDF237A PRIMED MDF

Also available in:

2-1/4, 3-1/4

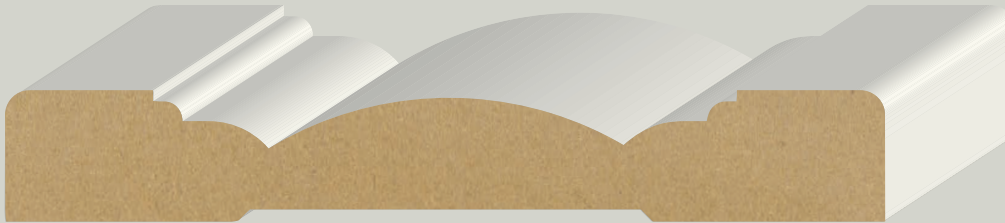

Boulder Casing

11/16 x 4-1/2

MDF159A PRIMED MDF

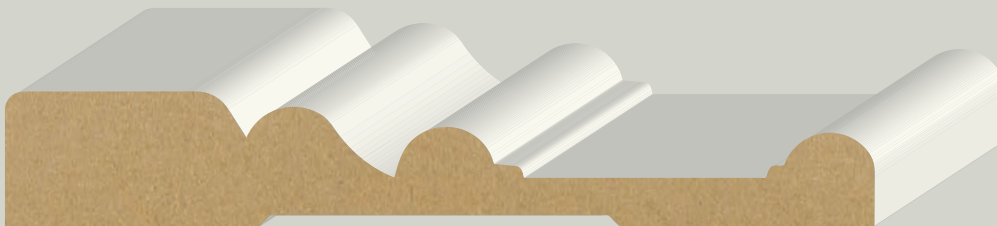

Howe Casing

3/4 x 4-1/2

MDF397A PRIMED MDF

Also available in:

2-7/16, 3-1/4

1-3/4" to 3" Chair Rail



Chair Rail

9/16 x 2-1/2

MDF452A PRIMED MDF



Coronado Casing/Chair Rail

11/16 x 2-5/8

MDF382A PRIMED MDF



Chair Rail

5/8 x 3

MDF136A PRIMED MDF



Chair Rail

11/16 x 1-3/4

MDF132A PRIMED MDF

1-1/2" to 2-3/4" Crown



Pediment Crown

1-1/4 x 1-1/2

MDF607A PRIMED MDF

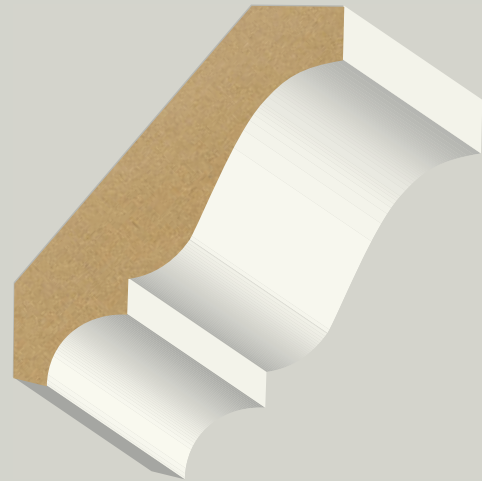

Crown

9/16 x 2-3/4

MDF284A PRIMED MDF

Also available in:

3-5/8, 4-1/4, 5-1/4, 7-1/4, 8-7/8

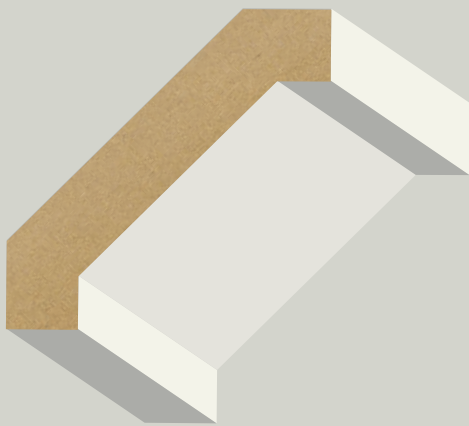

Craftsman Crown

9/16 x 2-3/8

MDF873A PRIMED MDF

Also available in:

4-1/4, 5-1/4

3" to 3-5/8" Crown

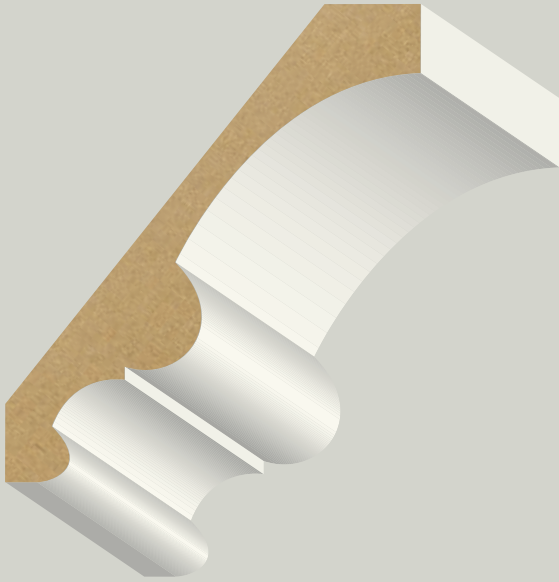

Single Bead Crown

1 1/16 x 3-1/4

MDF005A PRIMED MDF

Also available in:

4-5/8, 6-9/16

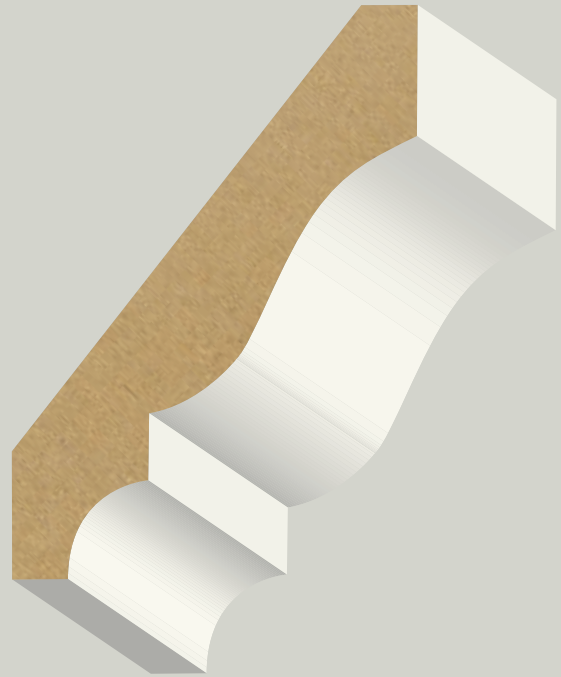

Crown

5/8 x 3-5/8

MDF286A PRIMED MDF

Also available in:

2-3/4, 4-1/4, 5-1/4, 7-1/4, 8-7/8



Pediment Crown

1-1/4 x 3

MDF613A PRIMED MDF

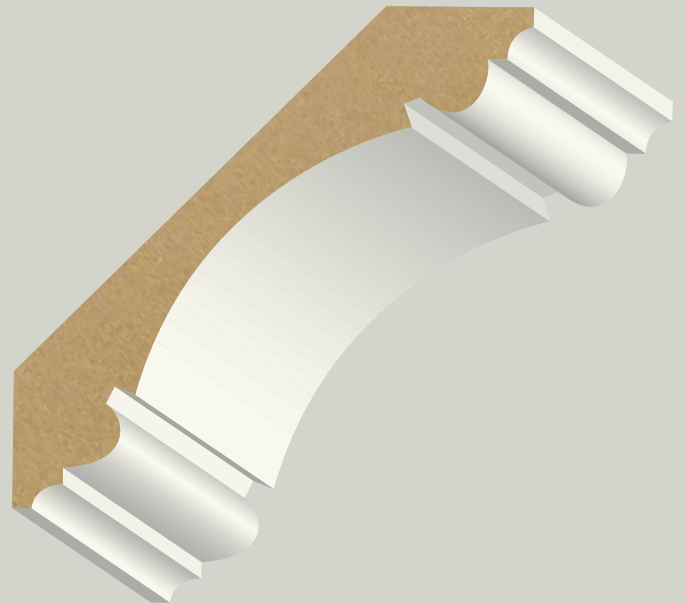

Double Bead Crown

1 1/16 x 3-7/16

MDF010A PRIMED MDF

Also available in:

4-5/8, 7-3/16



3-3/4" to 4-1/4" Crown

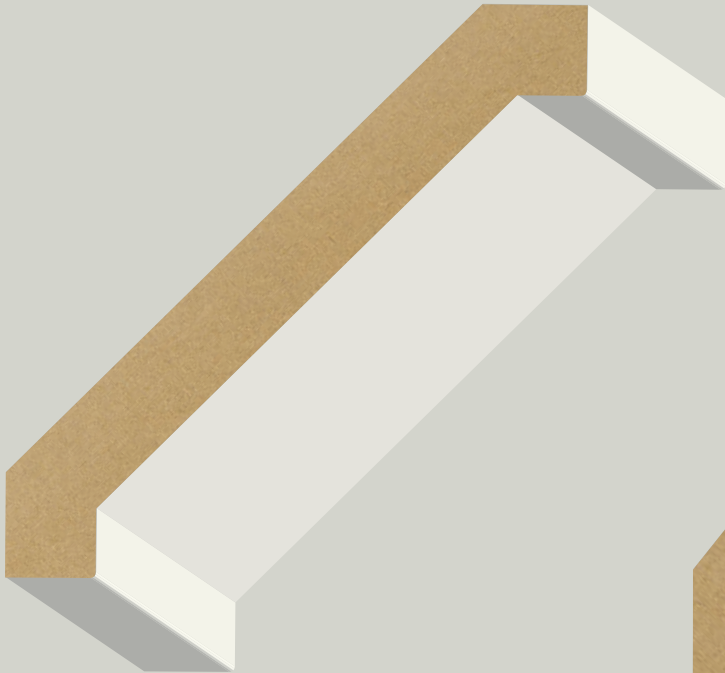

Craftsman Crown

1 1/16 x 4-1/4
MDF860A PRIMED MDF

Also available in:
2-3/8, 5-1/4

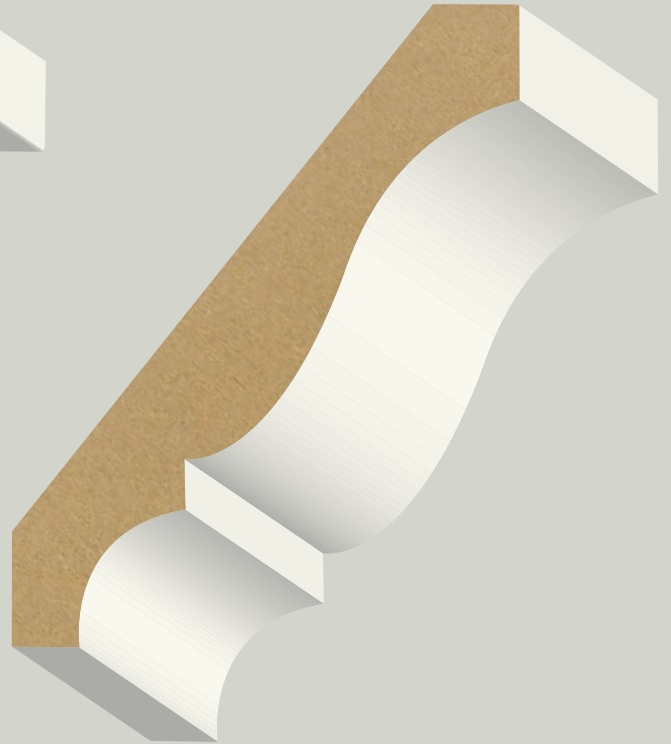

Crown

9/16 x 4-1/4
MDF285A PRIMED MDF

Also available in:
2-3/4, 3-5/8, 5-1/4, 7-1/4, 8-7/8

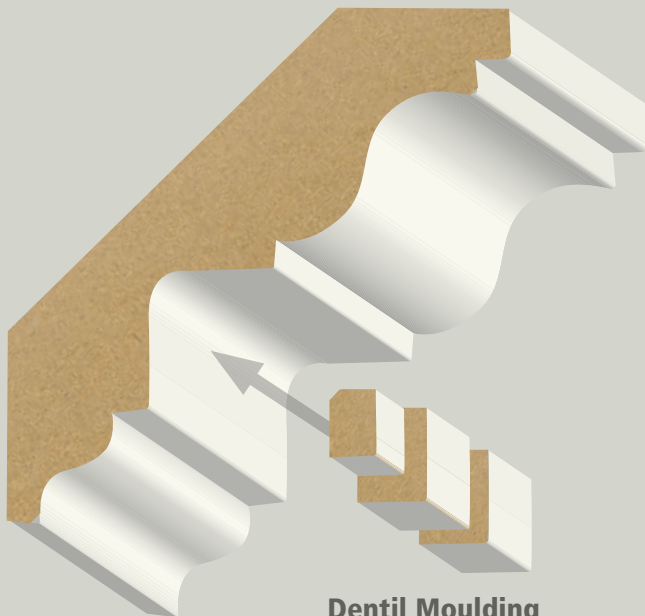

Dentil Ready Crown

7/8 x 3-3/4
MDF709A PRIMED MDF

Also available in:
5-1/2

Dentil Moulding

1/2 x 5/8
DNTL-709 HARDWOOD

4-1/4" Crown

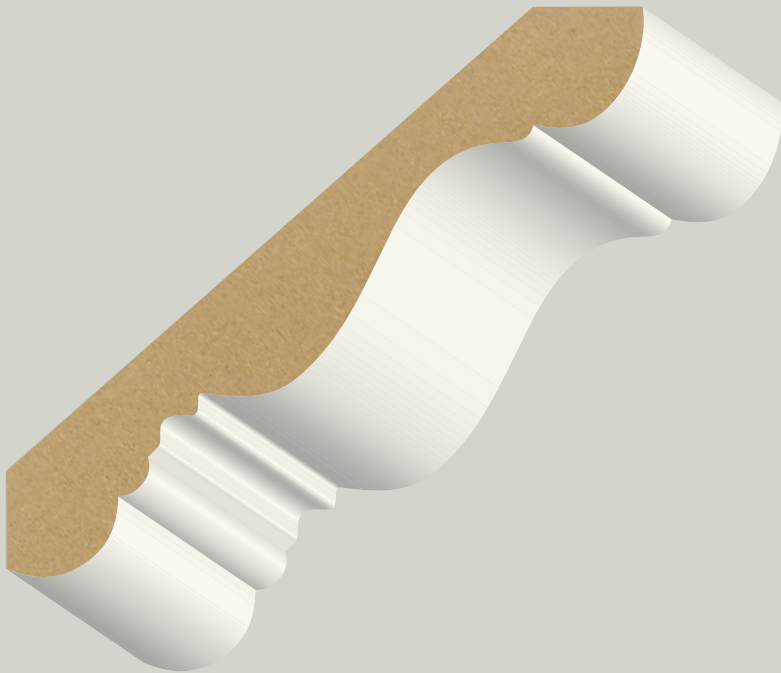

Charleston Crown

9/16 x 4-1/4

MDF566A PRIMED MDF

Also available in:
6"



Contemporary Crown

5/8 x 4-1/4

MDF95A PRIMED MDF

Also available in:
5-5/8, 7-1/4

4-1/4" to 4-5/8" Crown

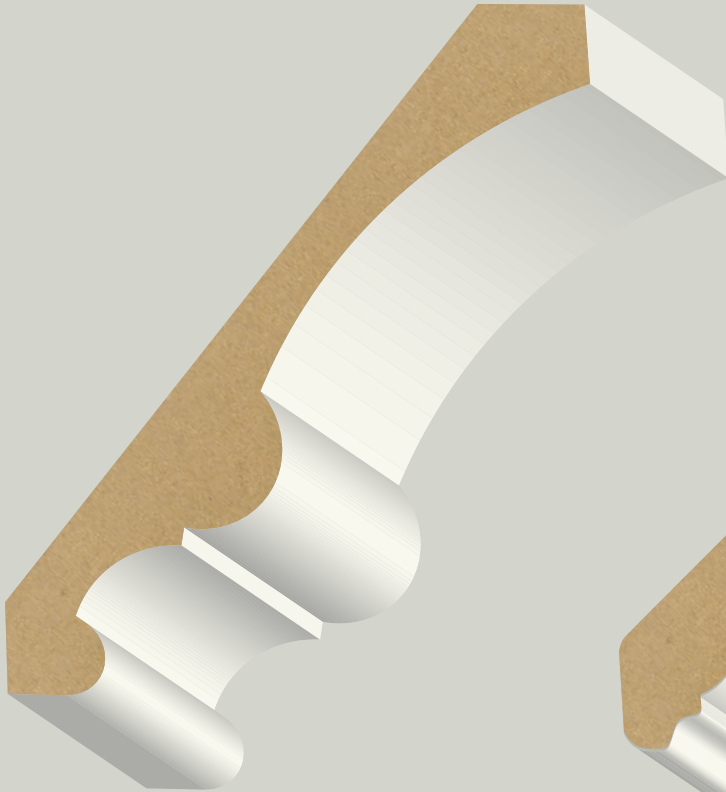

Single Bead Crown

11/16 x 4-5/8

MDF006A PRIMED MDF

Also available in:

3-1/4, 6-9/16

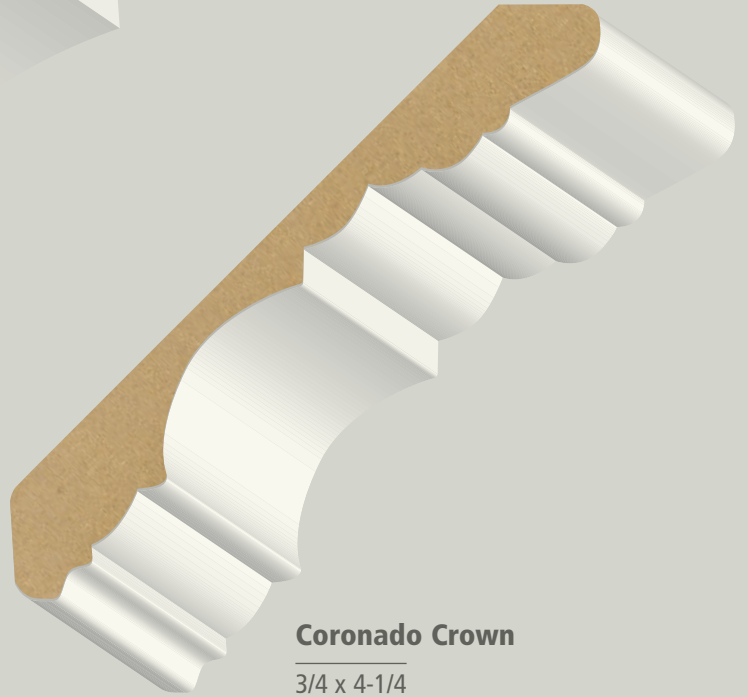

Coronado Crown

3/4 x 4-1/4

MDF108A PRIMED MDF

Also available in:

6-9/16



Cornice

3/4 x 4-5/8

MDF100A PRIMED MDF

Also available in:

6"

4-5/8" to 5-3/64" Crown

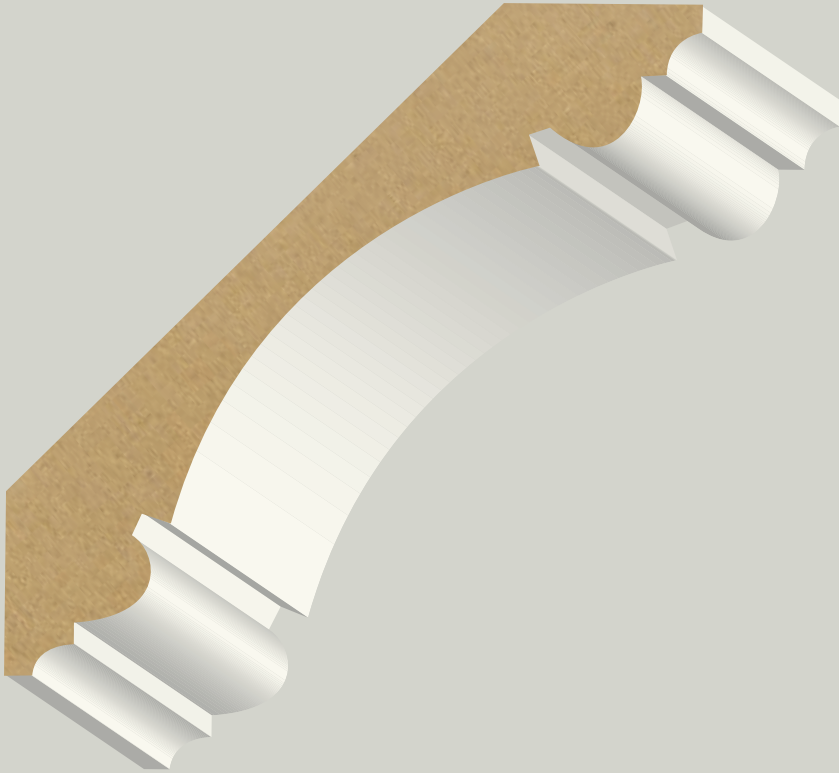

Double Bead Crown

7/8 x 4-5/8

MDF011A PRIMED MDF

*Also available in:
3-7/16, 7-3/16 .*

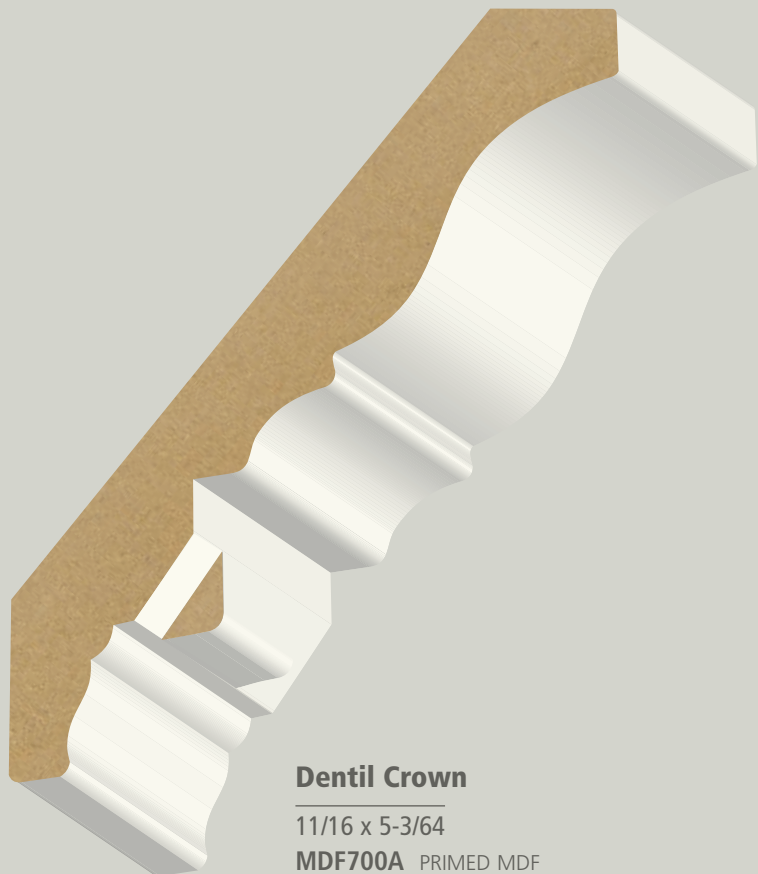

Dentil Crown

11/16 x 5-3/64

MDF700A PRIMED MDF

5-1/4" Crown



Crown

9/16 x 5-1/4

MDF567A PRIMED MDF

5/8 x 5-1/4

MDF65A PRIMED MDF

Also available in:

2-3/4, 3-5/8, 4-1/4, 7-1/4, 8-7/8



Craftsman Crown

11/16 x 5-1/4

MDF862A PRIMED MDF

Also available in:

2-3/8, 4-1/4

5-1/2" to 5-5/8" Crown

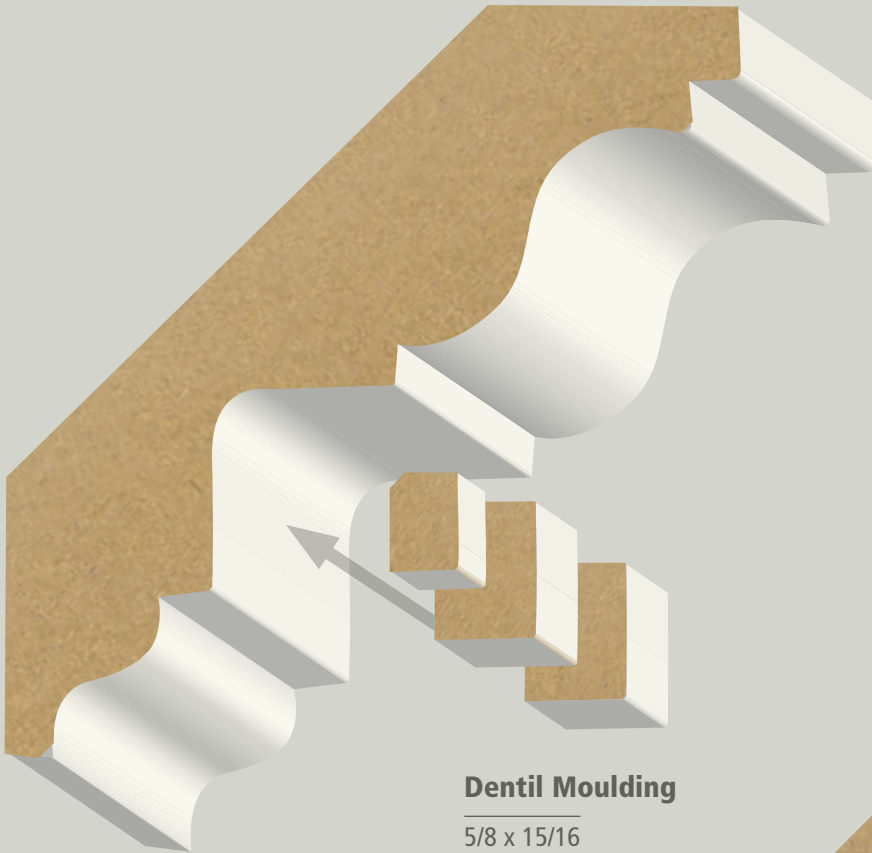

Dentil Ready Crown

7/8 x 5-1/2

MDF707A PRIMED MDF

Also available in:
3-3/4,

Dentil Moulding

5/8 x 15/16

DNTL-707 HARDWOOD

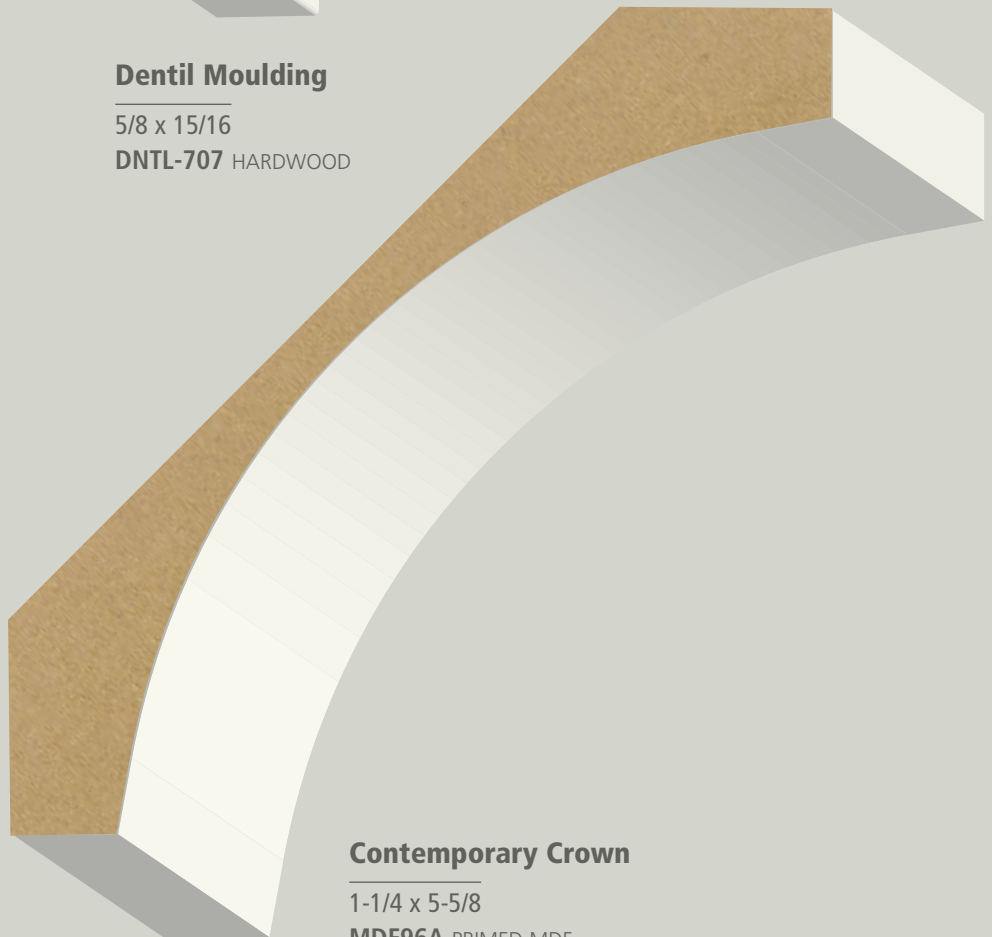

Contemporary Crown

1-1/4 x 5-5/8

MDF96A PRIMED MDF

Also available in:
4-1/4, 7-1/4,

6" Crown

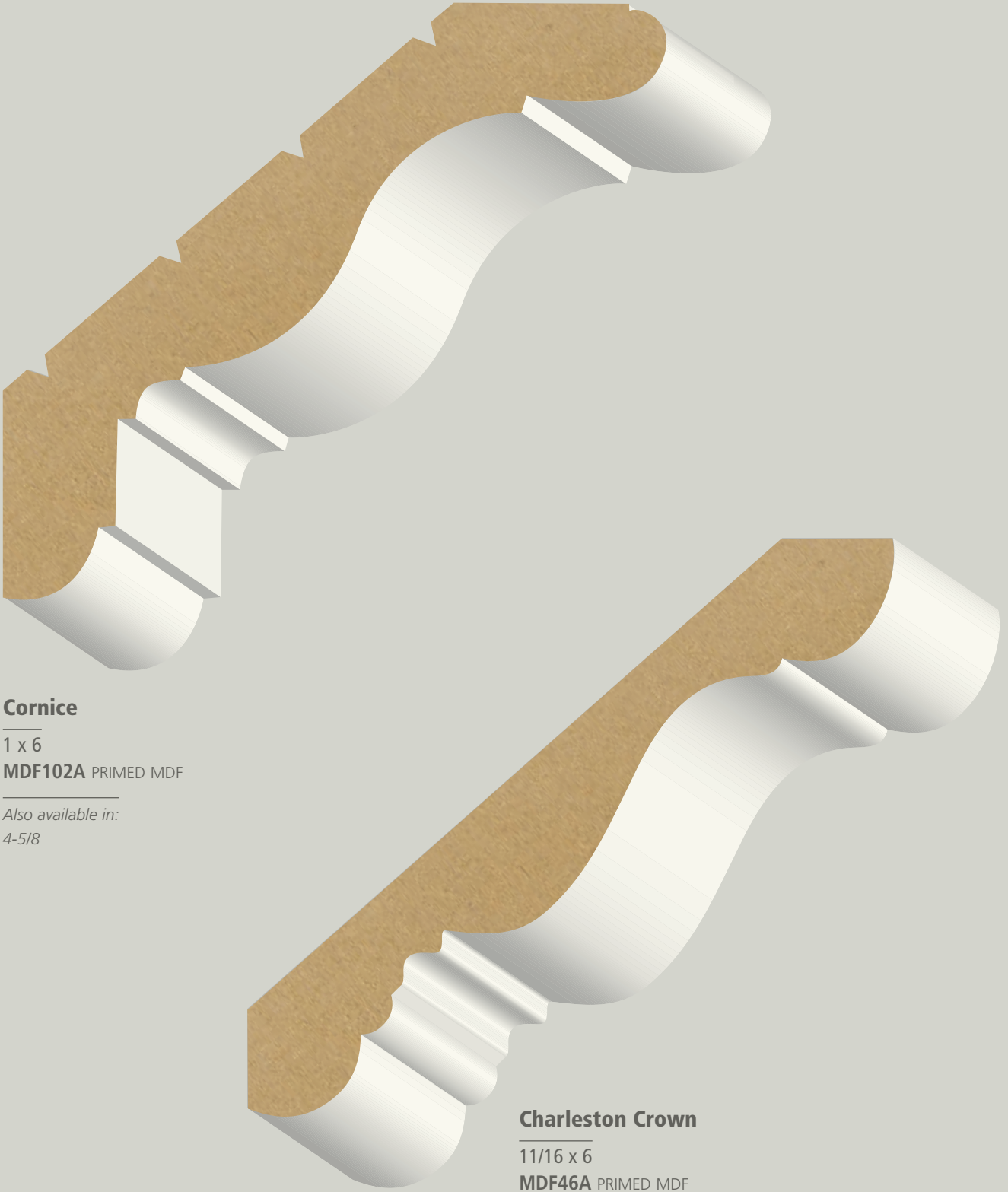

Cornice

1 x 6

MDF102A PRIMED MDF

Also available in:

4-5/8

Charleston Crown

1 1/16 x 6

MDF46A PRIMED MDF

Also available in:

4-1/4

MEDIUM DENSITY FIBERBOARD

70

6-5/16" Crown

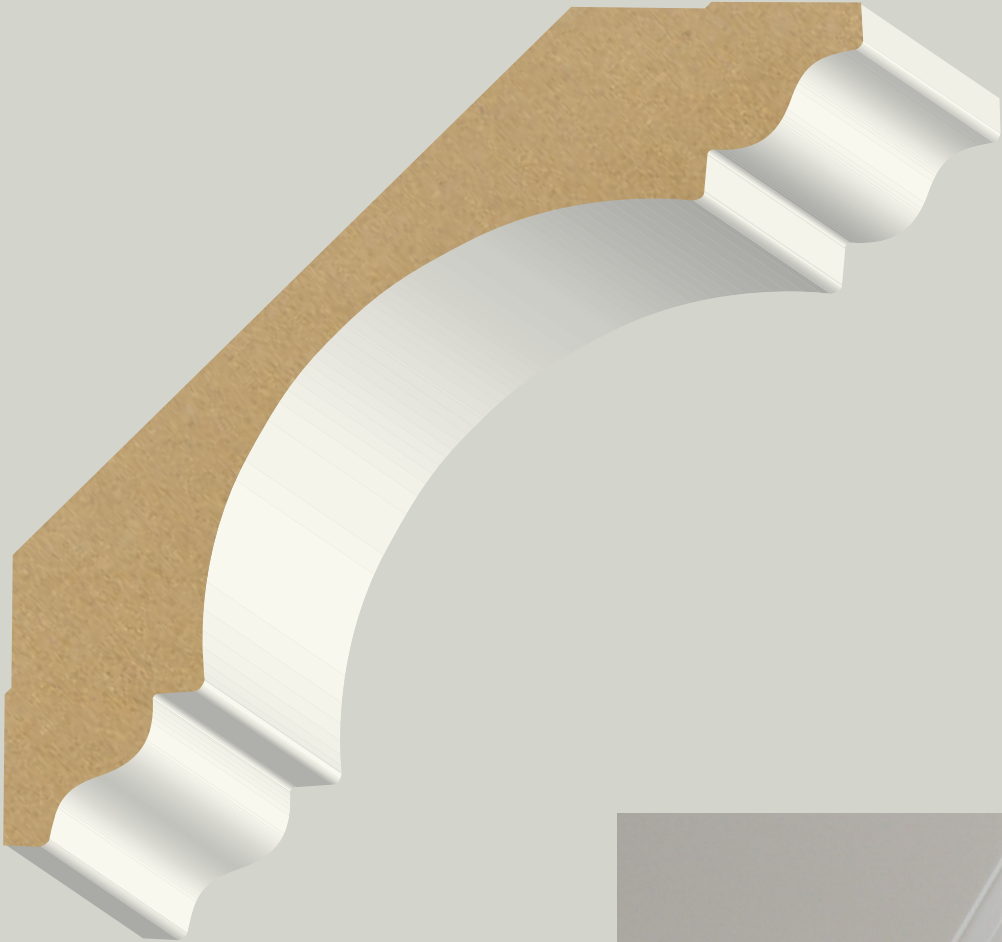

Regal Crown

1-3/16 x 6-5/16

MDF44A PRIMED MDF



6-7/16" to 6-7/8" Crown

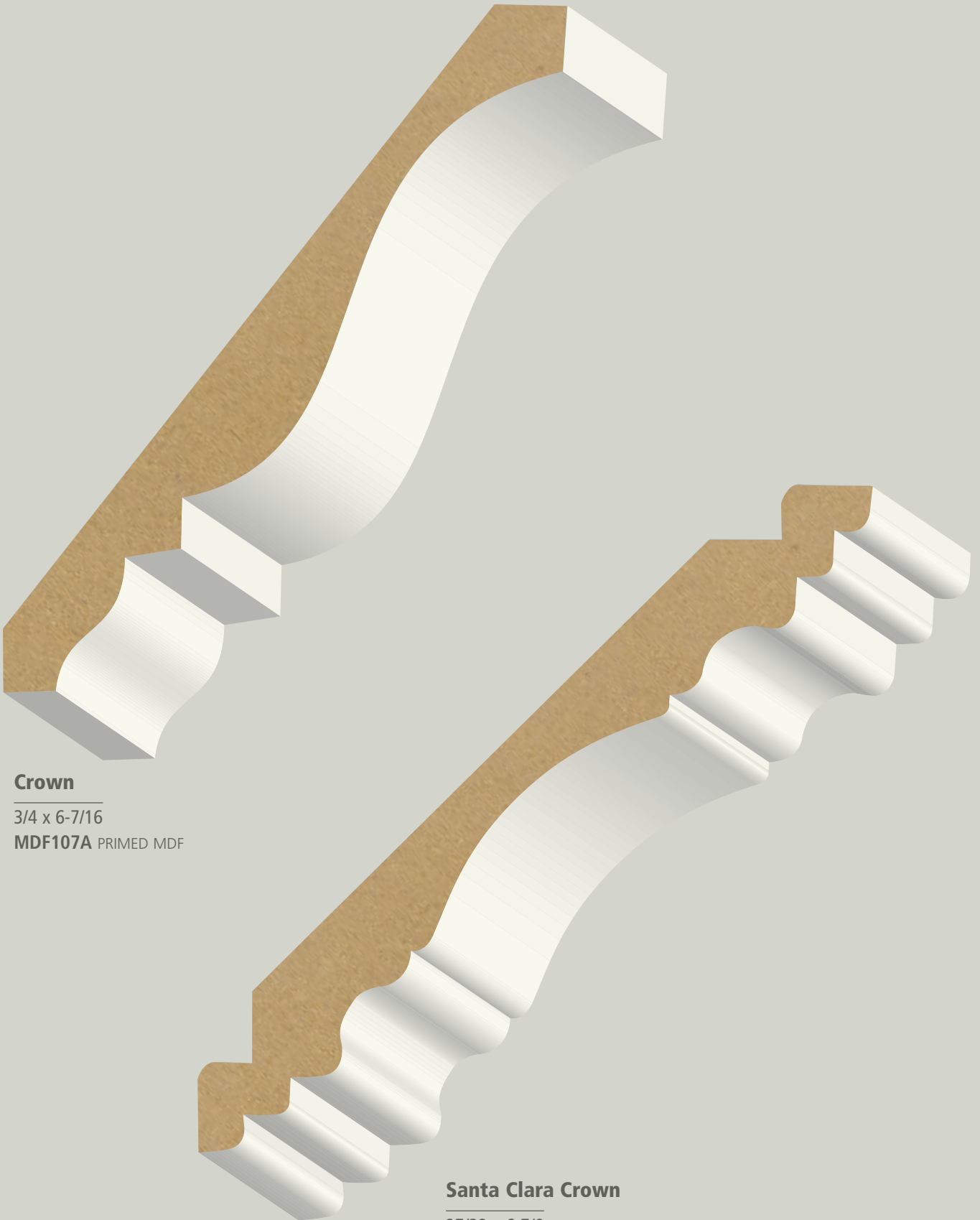

Crown

3/4 x 6-7/16

MDF107A PRIMED MDF

Santa Clara Crown

27/32 x 6-7/8

MDF289A PRIMED MDF

6-9/16" Crown

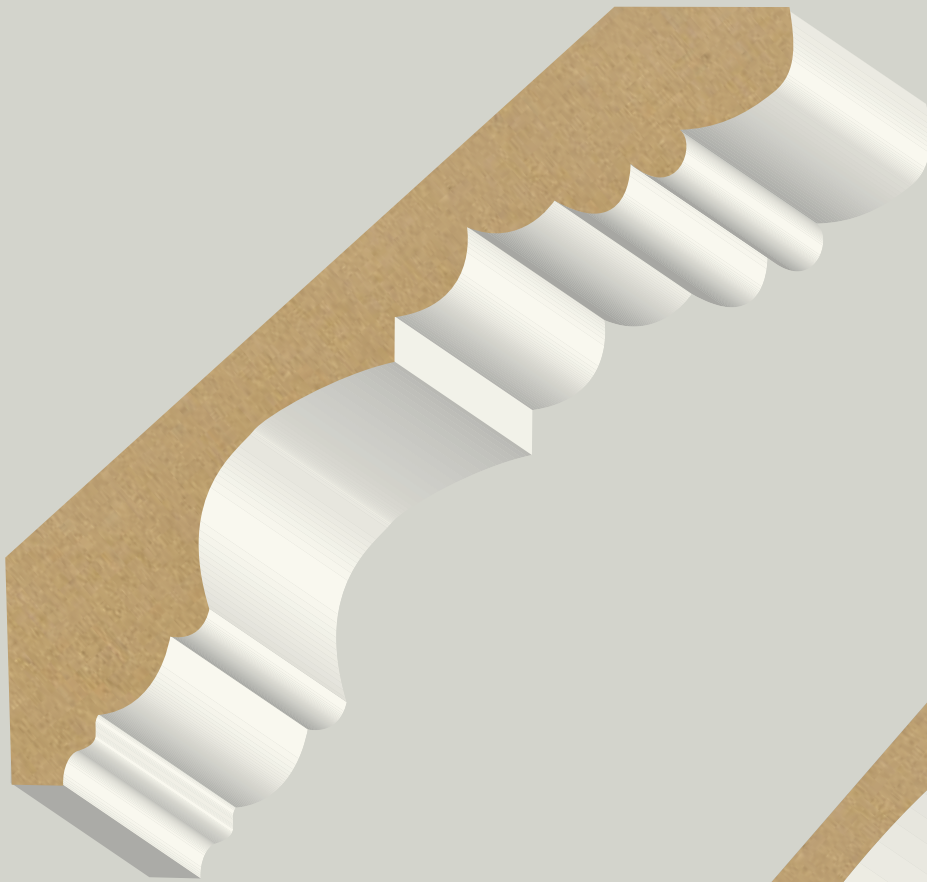

Coronado Crown

7/8 x 6-9/16

MDF104A PRIMED MDF

Also available in:

4-1/4



Single Bead Crown

7/8 x 6-9/16

MDF007A PRIMED MDF

Also available in:

3-1/4, 4-5/8

7-1/4" Crown

(Shown Here at 90% Actual Size)



Crown

9/16 x 7-1/4

MDF106A PRIMED MDF

Also available in:

2-3/4, 3-5/8, 4-1/4, 5-1/4, 8-7/8

Contemporary Crown

1-1/16 x 7-1/4

MDF98A PRIMED MDF

Also available in:

4-1/4, 5-5/8

7-3/16" to 8" Crown

(Shown Here at 90% Actual Size)



Double Bead Crown

1-1/8 x 7-3/16

MDF012A PRIMED MDF

Also available in:

3-7/16, 4-5/8

Coronado Crown

1 x 8

MDF103A PRIMED MDF

8" to 8-7/8" Crown

(Shown Here at 90% Actual Size)



Boulder Crown

1 x 8

MDF110A PRIMED MDF

Crown

1 1/16 x 8-7/8

MDF111A PRIMED MDF

Also available in:

2-3/4, 3-5/8, 4-1/4, 5-1/4, 7-1/4

1-3/4" to 2-5/8" Caps



Wainscoting Cap

3/4 x 2

MDF135A PRIMED MDF



Wainscoting Cap

1-1/8 x 1-3/4 x 16'

MDF51A PRIMED MDF



Newport Cap

3/4 x 2-5/8

MDF131A PRIMED MDF

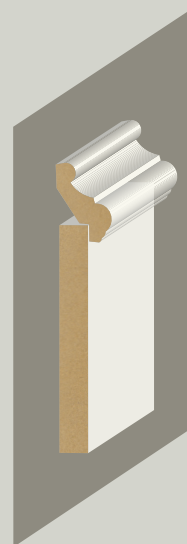

Caps Use:

Use caps over paneling, or wall boards to trim out and build up the wall treatment.

Wainscot

MEDIUM DENSITY FIBERBOARD

78



Wainscoting

3/8 x 5-3/4

MDF-50A PRIMED MDF



Wainscoting

5/8 x 3-1/4

MDF134A PRIMED MDF

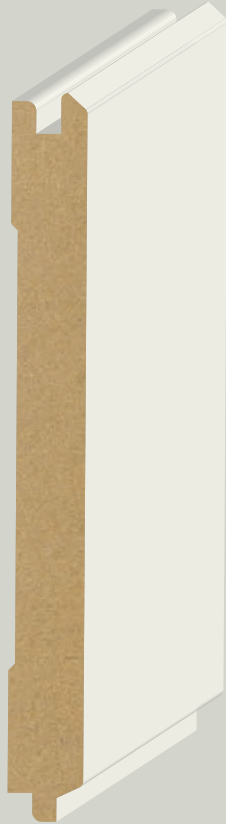

Smooth Wainscot

3/8 x 3-1/2

MDF130A PRIMED MDF



Shiplap Nickel Gap Profiles used in a contemporary bathroom.

Nickel Gap V-Groove

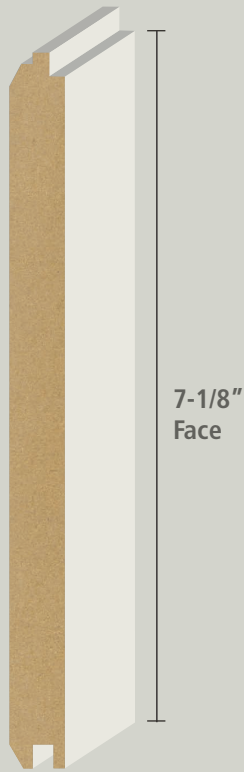

1x8 Reversible T&G Nickel Gap with V-Groove

5/8 x 7-3/8 (1/8" Gap / 7-1/8" Face)
MDF60A PRIMED MDF

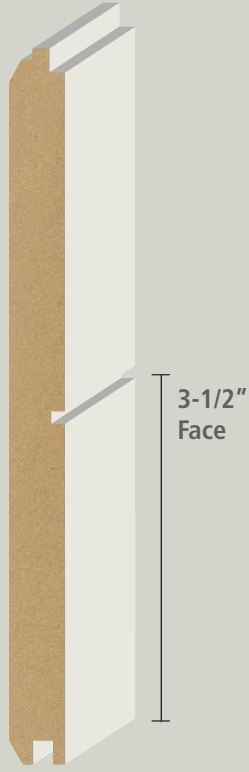

1x8 Reversible T&G Nickel Gap with V-Groove

5/8 x 7-3/8 (1/8" Gap / 3-1/2" Face)
MDF58A PRIMED MDF

Shiplap Nickel Gap Profiles

(Shown Here at 60% Actual Size)



Reversible 1x6 Nickel V Groove

5/8 x 5-1/2 (1/8" Gap / 5-1/4" Face)
MDF56A PRIMED MDF



Cap

1 x 2-1/2
MDF61A PRIMED MDF

*See Examples
Following Page*

Shiplap

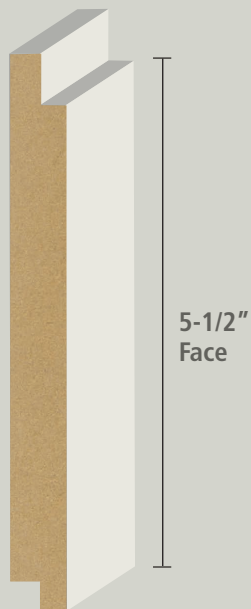

1x6 Shiplap – Nickel Gap Not Reversible

5/8 x 6 (3/16" Gap / 5-1/2" Face)
MDF57A PRIMED MDF

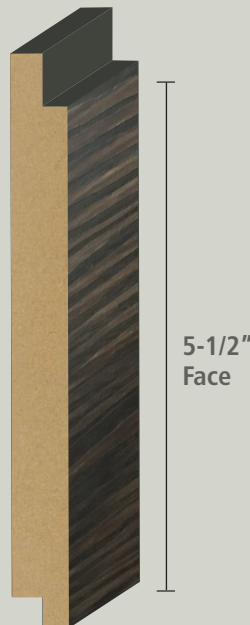
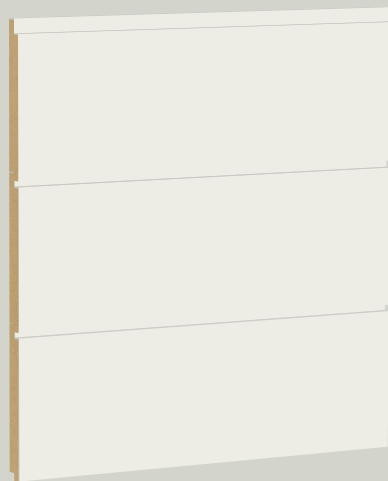

1x6 Shiplap – Nickel Gap With Raw Woodgrain – Not Reversible

5/8 x 6 (3/16" Gap / 5-1/2" Face)
MDF63AWG WOODGRAIN MDF



Stool



Window Sash O.G. Stool

Size:		
11/16 x 4-3/4	PRIMED MDF	MDF374A
11/16 x 5-1/4	PRIMED MDF	MDF376A
11/16 x 6-1/2	PRIMED MDF	MDF375A
11/16 x 7-1/4	PRIMED MDF	MDF377A



Window Sash O.G. Stool (Raw MDF)

11/16 x 4-3/4	11/16 x 7-1/4
MDF374 RAW MDF	MDF377 RAW MDF
11/16 x 5-1/4	
MDF376 RAW MDF	

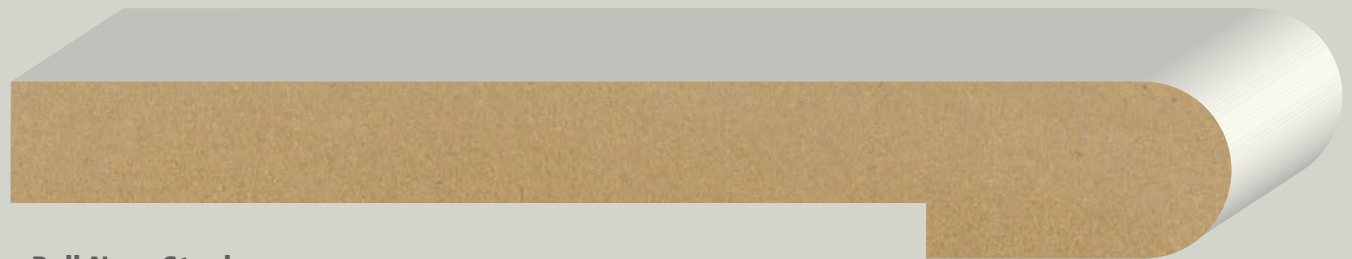

Bull Nose Stool

1-1/4 x 8-1/4
MDF408A PRIMED MDF

Stool

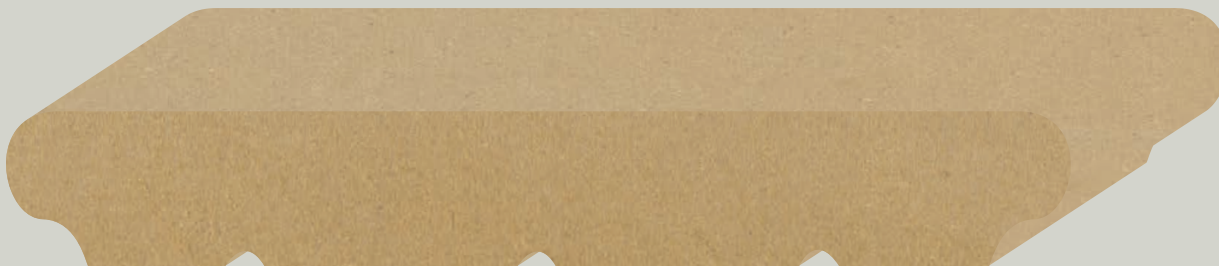

2 O.G. Cap

11/16 x 7-1/4

MDF400 RAW MDF



Square Edge Stool

1-1/4 x 8-1/4

MDF407A PRIMED MDF

Hook and Cleat



Raw Cleat (E1E)

9/16 x 1-1/2

MDF343 RAW MDF

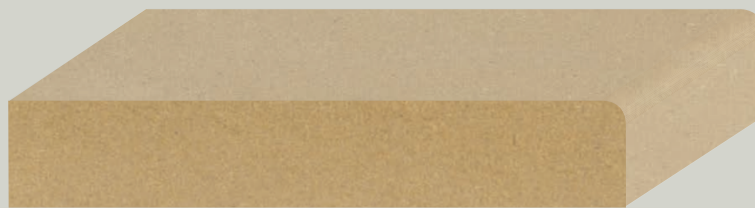

Raw Hook Strip

9/16 x 3-1/4

MDF305 RAW MDF

Primed S4S Boards

S4S Boards (Square Edge)



MDF1x2B 11/16 x 1-1/2
MDF1x3B 11/16 x 2-1/2
MDF1x4B 11/16 x 3-1/2

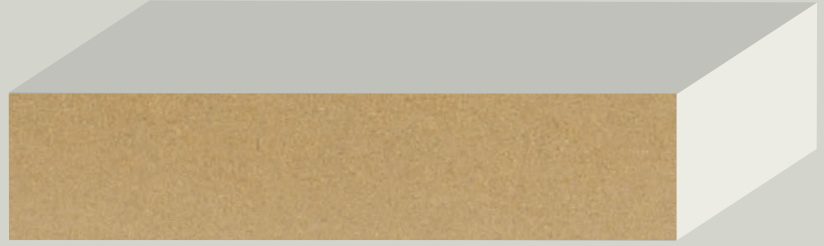

MDF1x6B 11/16 x 5-1/2
MDF1x8B 11/16 x 7-1/4
MDF1x12B 11/16 x 11-1/4
MDF5435B 5/4 x 3-1/2
MDF5455B 5/4 x 5-1/2
MDF54725B 5/4 x 7-1/4

S4S Boards/Wall Cap (Eased 2 Edges)

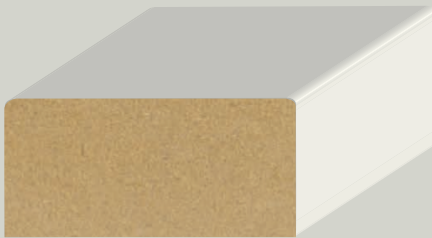

MDF1x2A 11/16 x 1-1/2
MDF1x3A 11/16 x 2-1/2

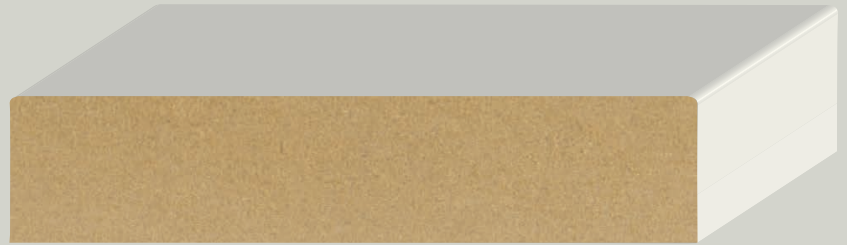

MDF1x4A 11/16 x 3-1/2
MDF1x6A 11/16 x 5-1/2
MDF1x8A 11/16 x 7-1/4
MDF1x12A 11/16 x 11-1/4
MDF5435A 5/4 x 3-1/2
MDF5455A 5/4 x 5-1/2
MDF54725A 5/4 x 7-1/4

R.E. Stop



R.E. Stop

7/16 x 1-1/4

MDF349A PRIMED MDF

MDF349AP 7' Pairs PRIMED MDF ⚙️

MDF349AP102 102" Pairs PRIMED MDF ⚙️



Raw Wall Cap

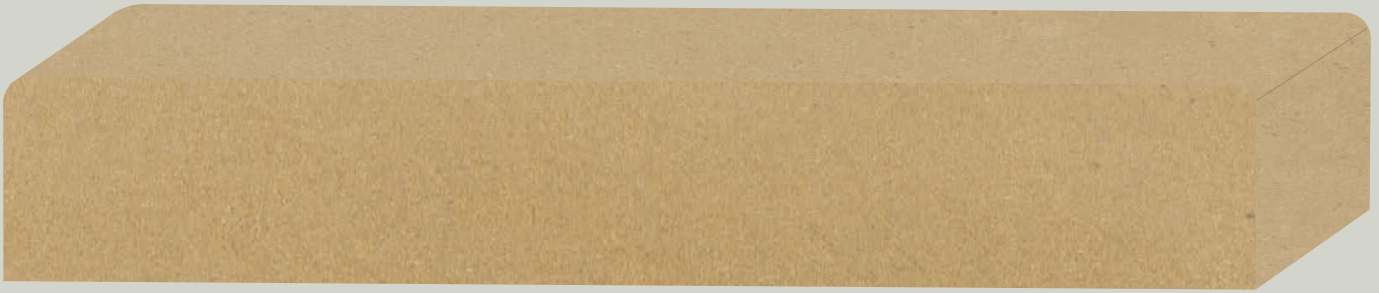

Raw E2E Wall Cap (Eased 2 Edges)

1-1/4 x 7-1/4

MDF402 RAW MDF

1-1/4 x 11-1/4

MDF405 RAW MDF

Jambstock

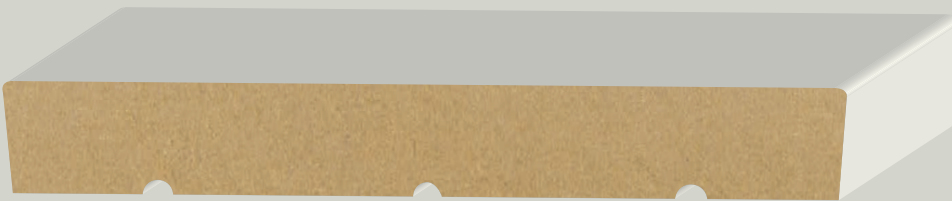

Jambstock (Please see website for additional dimensions)

Size:	Species:	Lineal:	Pairs:	8' Pairs:
4-9/16"	PRIMED MDF	MDF308A	MDF308AP	MDF308AP-96(*)
4-13/16"	PRIMED MDF	N/A	MDF309AP	MDF309AP-96(*)
5-1/4"	PRIMED MDF	N/A	MDF310AP	MDF310AP-96(*)
7-1/4"	PRIMED MDF	N/A	MDF312AP	MDF312AP-96(*)

(*)97" below dado.

INTERIOR JAMB SPECIFICATIONS:

81" below dado. No lug. Dado depth 5/16".

Heads cut 5/8" over opening.

Raw S4S Boards and Shelving



Raw MDF Bullnose Shelving

11/16 x 11-1/4

MDF1X12BN RAW MDF

11/16 x 15-1/4

MDF1X16BN RAW MDF

11/16 x 23-1/4

MDF1X24BN RAW MDF



Raw S4S Boards

MDF1x12 11/16 x 11-1/4 x 16'

MDF1x16 11/16 x 15-1/4 x 16'

MDF1x30 11/16 x 29-1/4 x 10'(& 16')

KS1X12MDF16 12mm x 11-1/4 x 16' (Skirtboard)



BNEF Particle Board Shelving

FB128 3/4 x 11-1/4 x 96"

FB1212 3/4 x 11-1/4 x 144"

FB1216 3/4 x 11-1/4 x 193"

FB168 3/4 X 15-1/4 x 96"

FB1612 3/4 x 15-1/4 x 144"

FB1616 3/4 X 15-1/4 x 193"

FB248 3/4 x 23-1/4 x 96"

FB2412 3/4 x 23-1/4 x 144"

FB2416 3/4 x 23-1/4 x 193"



PRIMED PINE MOULDING

**Floor, Ceiling, Wall, Window
and Door, Trim, Caps & Stops**

Primed Pine Moulding

About Primed Pine



Primed pine mouldings are a paint grade product made by trimming defects from common grade lumber to make short lengths of clear lumber. These pieces are then fingerjointed into longer lengths and manufactured into mouldings. This procedure helps reduce the tendency of the piece to twist or warp. A coat of primer is then applied by machine.

Final finishing requires applying one or two top coats of additional primer or paint as desired. Pre-priming at the mill is designed to be less expensive than painting by hand, and allows you to paint with your own choice of oil, lacquer, or acrylic based products.

Premium Primed Pine products have three coats of factory applied primer for an ultra-smooth surface, virtually eliminating visible joints and grain. No more than one finish coat of paint is needed in most cases.

Primed Pine, and Premium Primed Pine is lighter and easier to cut and install than MDF. They have a tendency to hold sharper edges found in intricate moulding profiles and are less prone to chip than MDF mouldings. They can be used in areas of limited moisture such as bathrooms provided they are thoroughly primed and sealed on cut edges.

Primed pine mouldings usually cost less than the stain grade equivalent because less expensive wood is used in the manufacturing process.

The Premium Primed mouldings in our Signature Series are available in distinct collections of matching bases, casings and crowns for customer convenience.





2-1/4" Base

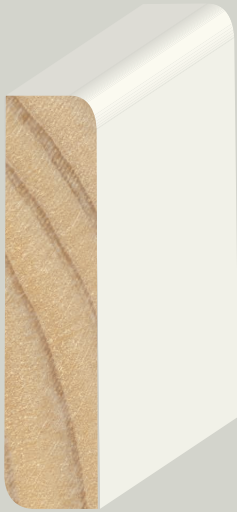

R.E. Reversible Base

1/2 x 2-1/4

P208PR PRIMED PINE

3/8 x 2-1/4

P212PR PRIMED PINE

CP212PR FSC PRIMED PINE

Also available in:

3-1/4



Streamline Base

1/2 x 2-1/4

P218PR PRIMED PINE



Moulded Base

1/2 x 2-1/4

P205PR PRIMED PINE



3-1/4" to 3-1/2" Base

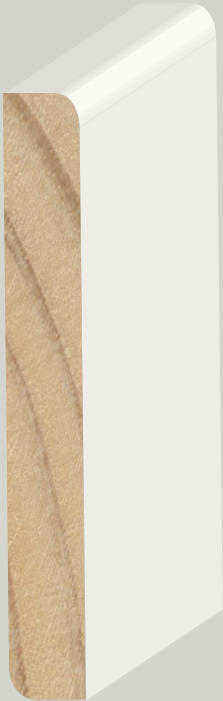

R.E. Reversible Base

1/2 x 3-1/4

P210PR PRIMED PINE

CP210PR FSC PRIMED PINE

3/8 x 3-1/4

P214PR PRIMED PINE

Also available in:
2-1/4

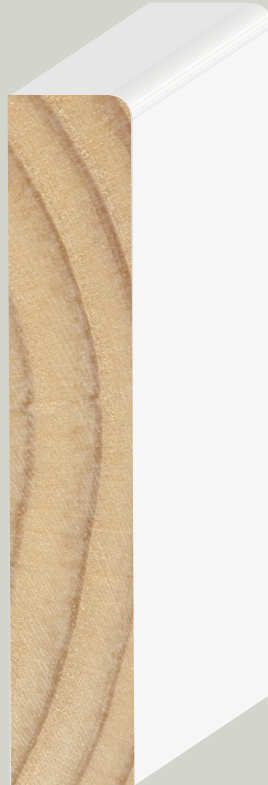

R.E. Base

9/16 x 3-1/2

P830PPR PREMIUM PRIMED PINE

Also available in:
5-1/2



Base Shoe

7/16 x 11/16

P229PR PRIMED PINE

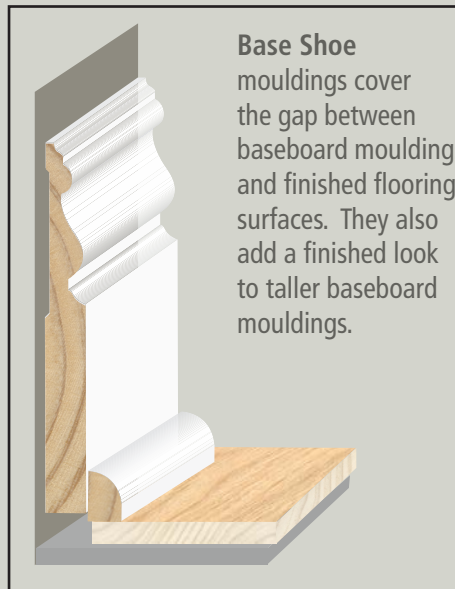

Base Shoe mouldings cover the gap between baseboard mouldings and finished flooring surfaces. They also add a finished look to taller baseboard mouldings.

3-1/4" to 3-7/16" Base

PRIMED PINE

90



Riviera Base

9/16 x 3-1/4

P213PR PRIMED PINE

Also available in:
5-1/4



Edgewood Base

9/16 x 3-1/4

P117PR PRIMED PINE

Also available in:
5-3/16



Peninsula Base

9/16 x 3-1/4

P111PR PRIMED PINE

Also available in:
5-1/4



Beaded Base

9/16 x 3-7/16

P835PPR PREMIUM PRIMED PINE

Also available in:
5-1/2

3-1/4" to 3-7/16" Base



Colonial Base

9/16 x 3-7/16

P015PR PRIMED PINE

Also available in:
5-7/16

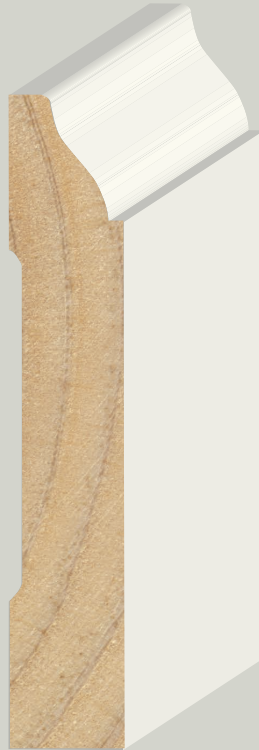

Coronado Base

9/16 x 3-1/4

P221PR PRIMED PINE

CP221PR FSC PRIMED PINE

Also available in:
4-1/4, 5-1/4



Montecito Base

9/16 x 3-1/4

P014PR PRIMED PINE

Also available in:
5-1/4



Santa Fe Base

9/16 x 3-7/16

P203PR PRIMED PINE

Also available in:
4-1/2, 5-7/16

4-1/4" to 4-1/2" Base

PRIMED PINE

92



Coronado Base

9/16 x 4-1/4

P222PR PRIMED PINE

Also available in:

3-1/4, 5-1/4



Solana Base

11/16 x 4-1/4

P416PR PRIMED PINE



Santa Fe Base

9/16 x 4-1/2

P233PR PRIMED PINE

Also available in:

3-7/16, 5-7/16

5-3/16" to 5-1/4" Base



Edgewood Base

9/16 x 5-3/16

P118PR PRIMED PINE

Also available in:

3-1/4



Coronado Base

9/16 x 5-1/4

P223PR PRIMED PINE

CP223PR FSC PRIMED PINE

Also available in:

3-1/4, 4-1/4



Sierra Base

11/16 x 5-1/4

P217PR PRIMED PINE

5-1/4" Base



Peninsula Base

9/16 x 5-1/4

P112PR PRIMED PINE

Also available in:
3-1/4

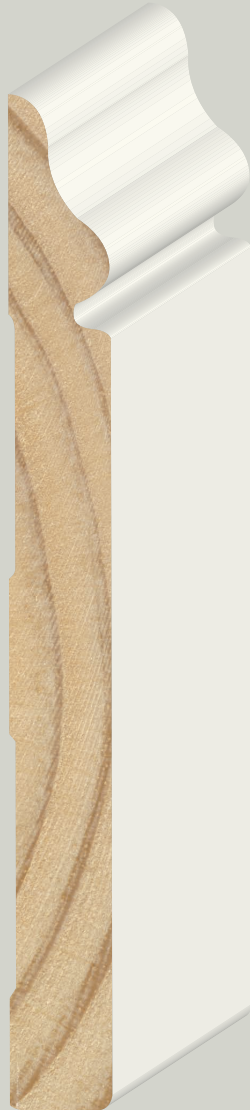

Montecito Base

9/16 x 5-1/4

P026PR PRIMED PINE



Monterey Base

9/16 x 5-1/4

P839PPR PREMIUM PRIMED PINE

Also available in:
7-1/4

5-1/4" to 5-7/16" Base

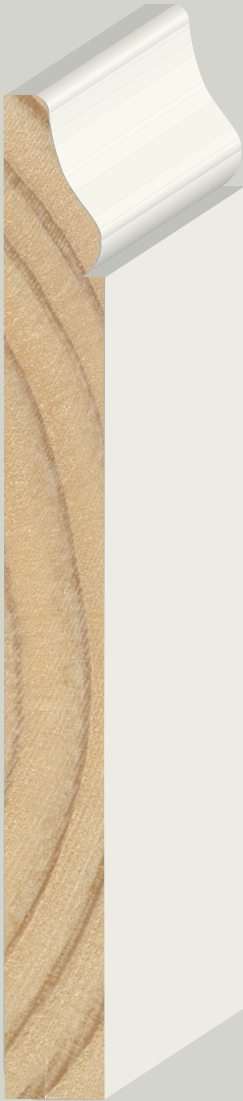

Riviera Base

9/16 x 5-1/4

P215PR PRIMED PINE

Also available in:
3-1/4



Lombard Base

11/16 x 5-1/4

P182PR PRIMED PINE

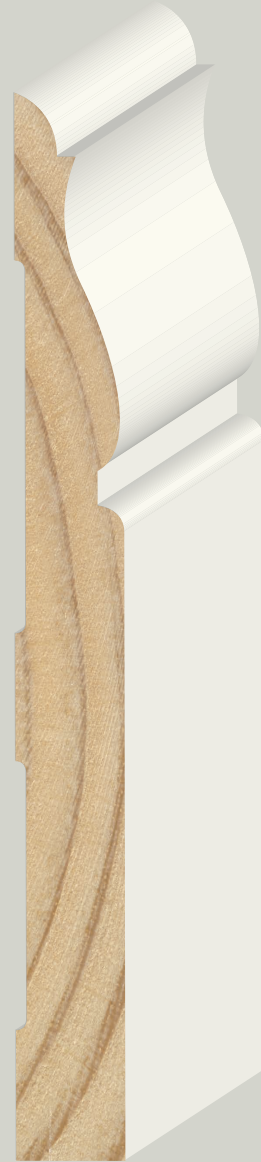

Colonial Base

9/16 x 5-7/16

P016PR PRIMED PINE

5-7/16" to 5-1/2" Base



Santa Fe Base

9/16 x 5-7/16

P009PR PRIMED PINE

Also available in:

3-7/16, 4-1/2



Beaded Base

9/16 x 5-1/2

P837PPR PREMIUM PRIMED PINE

Also available in:

3-7/16

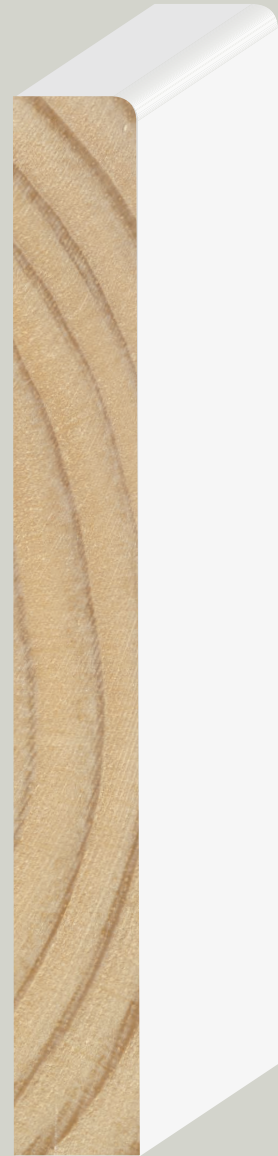

Single R.E. Base

9/16 x 5-1/2

P833PPR PREMIUM PRIMED PINE

1/2 x 5-1/2

P206PR PRIMED PINE

Also available in:

3-1/2

7-1/4" Base

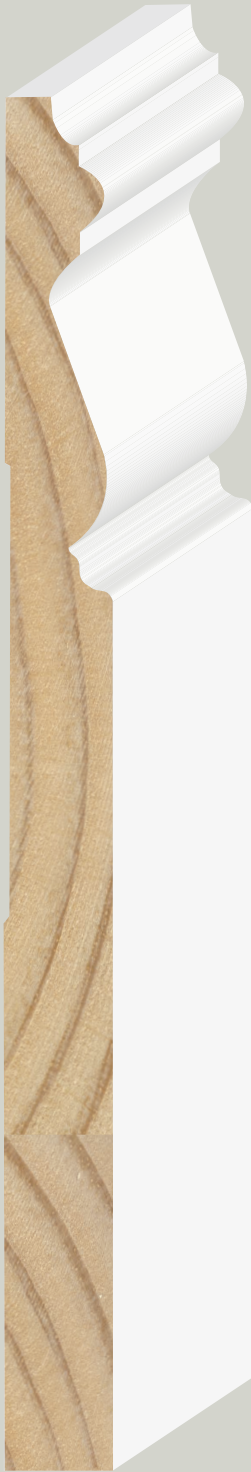

Monterey Base

9/16 x 7-1/4

P840PPR PREMIUM PRIMED PINE

Also available in:

5-1/4



Usage Idea



PRIMED PINE

1-5/8" Casing



Round Edge Casing

9/16 x 1-5/8

P232PR PRIMED PINE

Also available in:

2-1/4, 2-1/2, 3-1/4, 3-1/2, 4-1/2



Moulded Casing

5/8 x 1-5/8

P238PR PRIMED PINE



Bevel Casing

5/8 x 1-5/8

P256PR PRIMED PINE ⚙️

CP256PR FSC PRIMED PINE

Also available in:

2-1/4

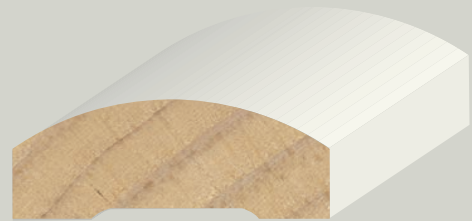

Oval Casing

9/16 x 1-5/8

P244PR PRIMED PINE

Also available in:

2-1/4

2-1/4" Casing



Bevel Casing

5/8 x 2-1/4

P258PR PRIMED PINE ⚙️

P258FJ RAW FJ PINE (⚙️ ONLY)

Also available in:

1-5/8



Round Edge Casing

9/16 x 2-1/4

P234PR PRIMED PINE ⚙️

CP234PR FSC PRIMED PINE

3/4 x 2-1/2

P845PPR PREMIUM PRIMED PINE

Also available in:

1-5/8, 3-1/4, 3-1/2, 4-1/2



Colonial Casing/356

11/16 x 2-1/4

P239PR PRIMED PINE ⚙️

P239FJ RAW FJ PINE ⚙️



Oval Casing

9/16 x 2-1/4

P246PR PRIMED PINE

Also available in:

1-5/8



Anderson Casing

5/8 x 2-1/4

P241PR PRIMED PINE



Step Casing

5/8 x 2-1/4

P250PR PRIMED PINE

2-1/4" to 2-1/2" Casing



Moulded Casing

5/8 x 2-1/4

P240PR PRIMED PINE 

CP240PR FSC PRIMED PINE

Also available in:

1-5/8, 3-1/4



Single Bead Casing

3/4 x 2-1/2

P852PPR PREMIUM PRIMED PINE

Also available in:

3-1/4, 4-1/4

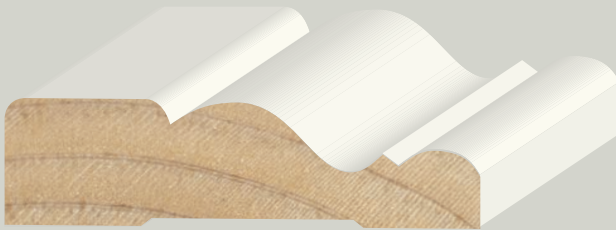

Montana Casing

11/16 x 2-7/16

P114PR PRIMED PINE



Flute & Reed Casing

11/16 x 2-1/4

P027PR PRIMED PINE

Also available in:

3-1/4, 4-1/4

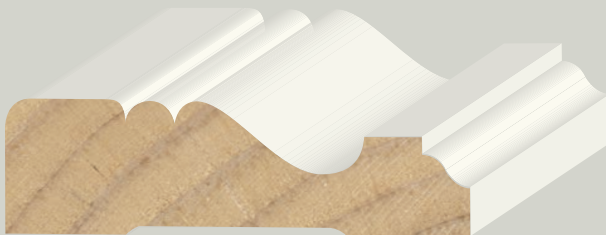

Carolina Casing

11/16 x 2-7/16

P013PR PRIMED PINE

Also available in:

3-1/4

2-7/16" to 2-5/8" Casing

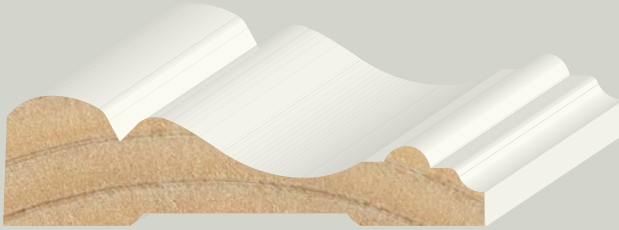

Honolulu Casing

11/16 x 2-1/2

P201PR PRIMED PINE



Coronado Chair Rail/Casing

5/8 x 2-5/8

P382PR PRIMED PINE



Santa Fe Casing

11/16 x 2-7/16

P008PR PRIMED PINE

Also available in:

3-1/2

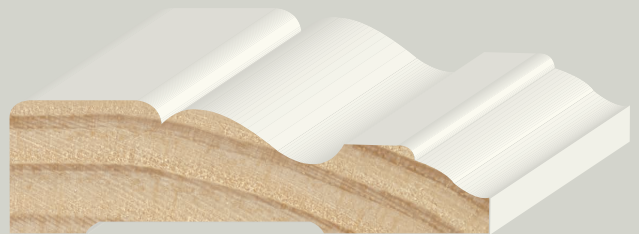

Riviera Casing

11/16 x 2-1/2

P385PR PRIMED PINE 

CP385PR FSC PRIMED PINE



Victorian Casing

11/16 x 2-1/2

P262PR PRIMED PINE

Also available in:

3-1/4

3-1/4" Casing



Flute & Reed Casing

1 1/16 x 3-1/4

P386PR PRIMED PINE

Also available in:
2-1/4, 4-1/4



Single Bead Casing

7/8 x 3-1/4

P853PPR PREMIUM PRIMED PINE

Also available in:
2-1/2, 4-1/4



Moulded Casing

5/8 x 3-1/4

P242PR PRIMED PINE
CP242PR FSC PRIMED PINE

Also available in:
1-5/8, 2-1/4



Davis Casing

5/8 x 3-1/4

P480PR PRIMED PINE

⚙ Available in Cut to Length)

WWW.KELLEHER.COM

3-3/16" to 3-1/4" Casing



Mission Casing

1 1/16 x 3-3/16

P116PR PRIMED PINE

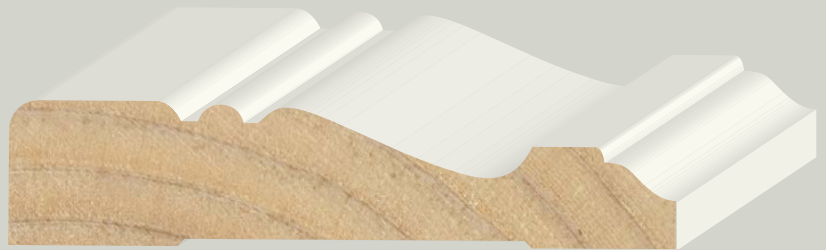

Carolina Casing

1 1/16 x 3-1/4

P-388PR PRIMED PINE

Also available in:

2-7/16

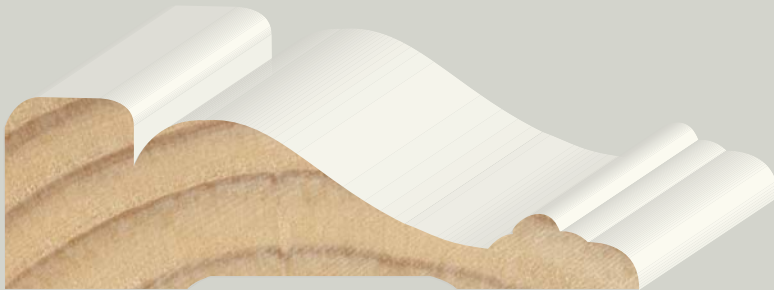

49er Casing

1 x 3-1/4

P380PR PRIMED PINE

Also available in:

2-1/2



Monterey Casing

1 1/16 x 3-1/4

P856PPR PREMIUM PRIMED PINE

Also available in:

4-1/2

3-1/4" to 3-1/2" Casing



Howe Casing

1-1/16 x 3-1/4

P387PR PRIMED PINE

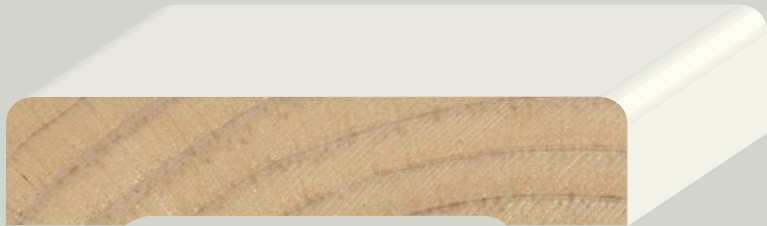

Round Edge Casing

9/16 x 3-1/4

P236PR PRIMED PINE

3/4 x 3-1/2

P846PPR PREMIUM PRIMED PINE

Also available in:

1-5/8, 2-1/4, 2-1/2, 4-1/2



3-7/16" to 3-1/2" Casing



Shasta Casing

1 1/16 x 3-7/16

P391PR PRIMED PINE

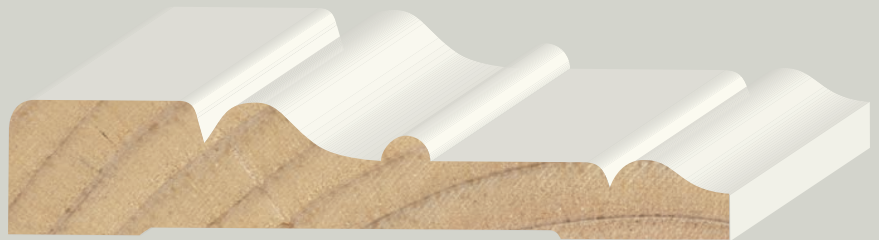

Beaded Colonial Casing

1 1/16 x 3-7/16

P001PR PRIMED PINE



Santa Fe Casing

1-1/16 x 3-1/2

P393PR PRIMED PINE

Also available in:

2-7/16



Valley Casing

1 1/16 x 3-1/2

P243PR PRIMED PINE



Single Bead Casing

1 x 4-1/4

P854PPR PREMIUM PRIMED PINE

Also available in:

2-1/2, 3-1/4



Flute & Reed Casing

11/16 x 4-1/4

P389PR PRIMED PINE

Also available in:

2-1/4, 3-1/4

4-1/2" Casing

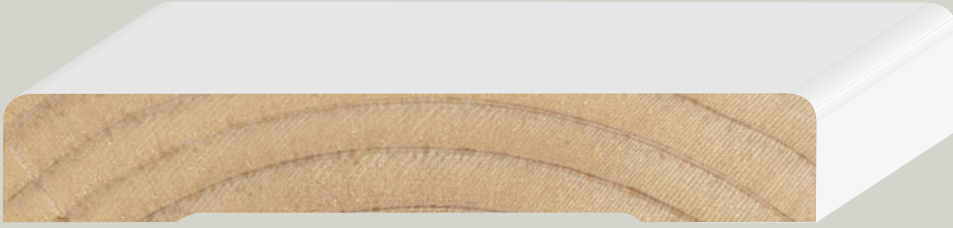

Round Edge Casing

3/4 x 4-1/2

P847PPR PREMIUM PRIMED PINE

Also available in:

1-5/8, 2-1/4, 2-1/2, 3-1/4



Monterey Casing

1-1/4 x 4-1/2

P857PPR PREMIUM PRIMED PINE

Also available in:

3-1/4

1-3/4" to 3" Chair Rail



Chair Rail

11/16 x 1-3/4

P894PPR PREMIUM PRIMED PINE



Chair Rail

3/4 x 2-1/8

P390PR PRIMED PINE

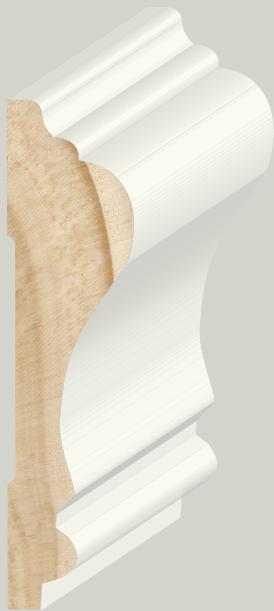

Coronado Chair Rail/Casing

5/8 x 2-5/8

P382PR PRIMED PINE



Bolection Mould

1-1/16 x 3

P199PR PRIMED PINE



PRIMED PINE

110

1-5/8" to 2-3/4" Crown

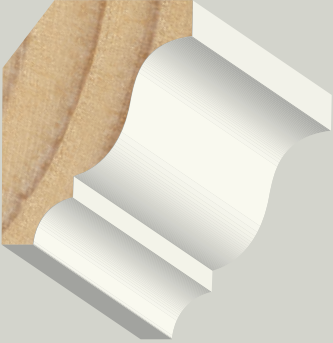

Crown

9/16 x 1-5/8

P282PR PRIMED PINE

9/16 x 2-1/4

P083PR PRIMED PINE

Also available in:

2-3/4, 3-1/4, 3-5/8, 4-5/8, 5-1/4



Bed Crown

1-7/16 x 1-3/4

P609PR PRIMED PINE

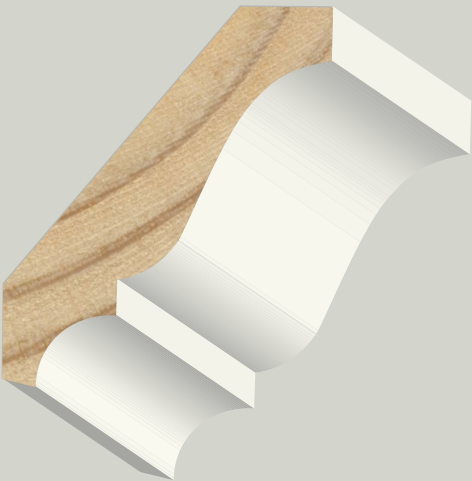

Crown

9/16 x 2-3/4

P284PR PRIMED PINE

CP284PR FSC PRIMED PINE

Also available in:

1-5/8, 2-1/4, 3-1/4, 3-5/8, 4-5/8, 5-1/4

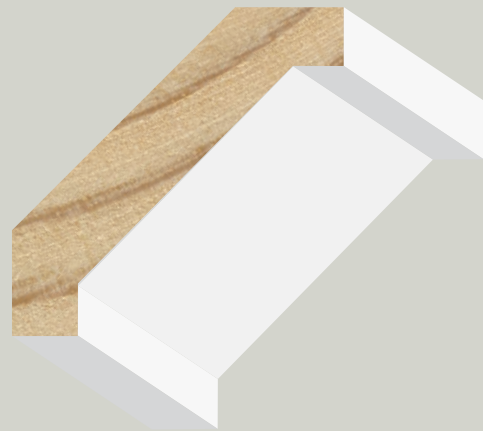

Craftsman Crown

11/16 x 2-3/8

P873PPR PREMIUM PRIMED PINE

Also available in:

4", 5-1/4

3-1/8" to 3-5/8" Crown

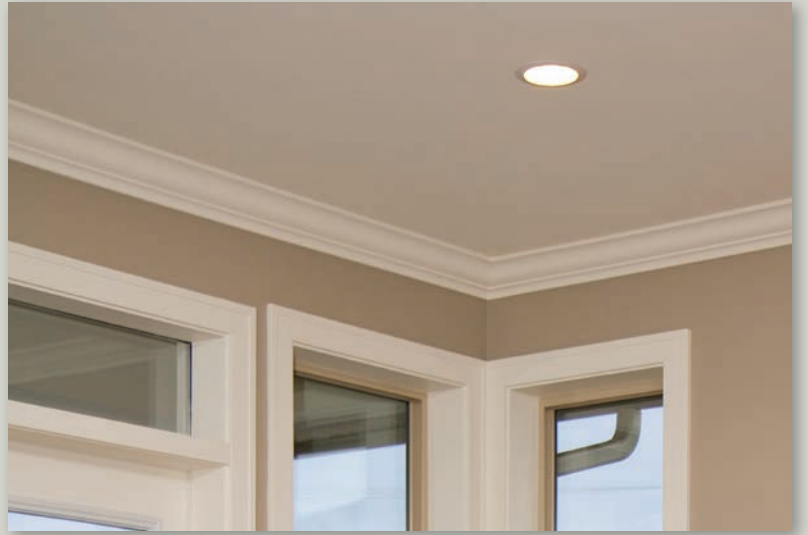
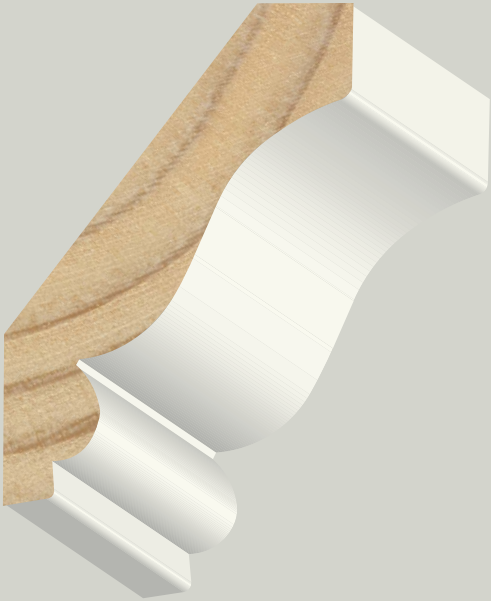

Edge Bead Crown

11/16 x 3-1/8

P279PR PRIMED PINE



Single Bead Crown

11/16 x 3-1/4

P865PPR PREMIUM PRIMED PINE

Also available in:
4-5/8, 6-1/2

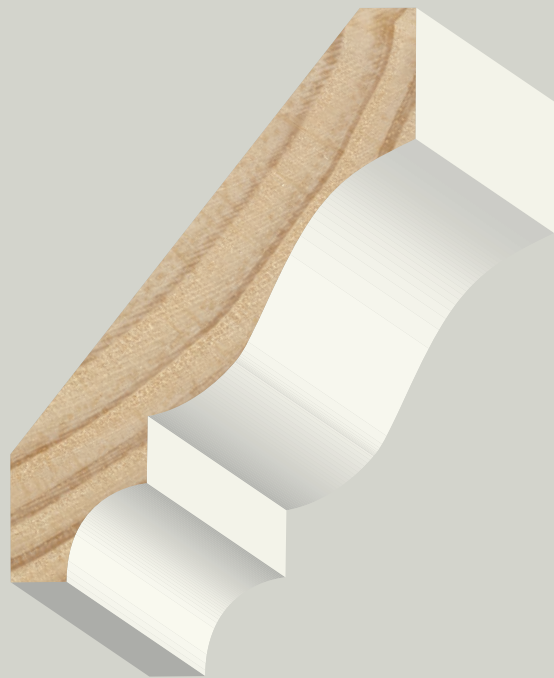

Crown

9/16 x 3-1/4

P281PR PRIMED PINE

5/8 x 3-5/8

P286PR PRIMED PINE

CP286PR FSC PRIMED PINE

Also available in:
1-5/8, 2-1/4, 2-3/4, 4-5/8, 5-1/4

3-7/16" to 4-3/8" Crown



Double Bead Crown

1 1/16 x 3-7/16

P010PR PRIMED PINE

Also available in:

4-15/16, 7-3/16



Craftsman Crown

1 1/16 x 4

P860PPR PREMIUM PRIMED PINE

Also available in:

2-3/8, 5-1/4



Coronado Crown

3/4 x 4-3/8

P610PR PRIMED PINE

4-1/4" to 4-5/8" Crown

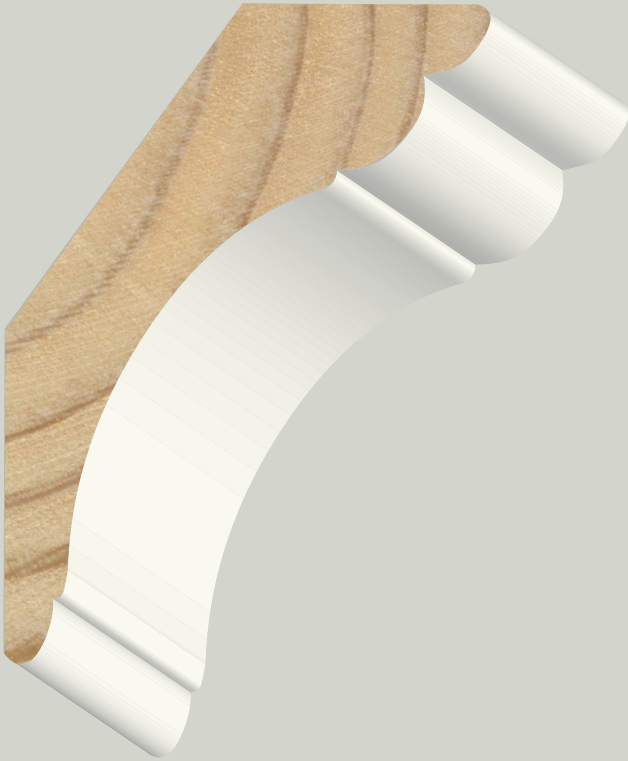

Colonial Crown

1-1/8 x 4-5/16

P611PR PRIMED PINE



Crown

9/16 x 4-1/4

P283PR PRIMED PINE

Also available in:

5-1/4, 6-3/8

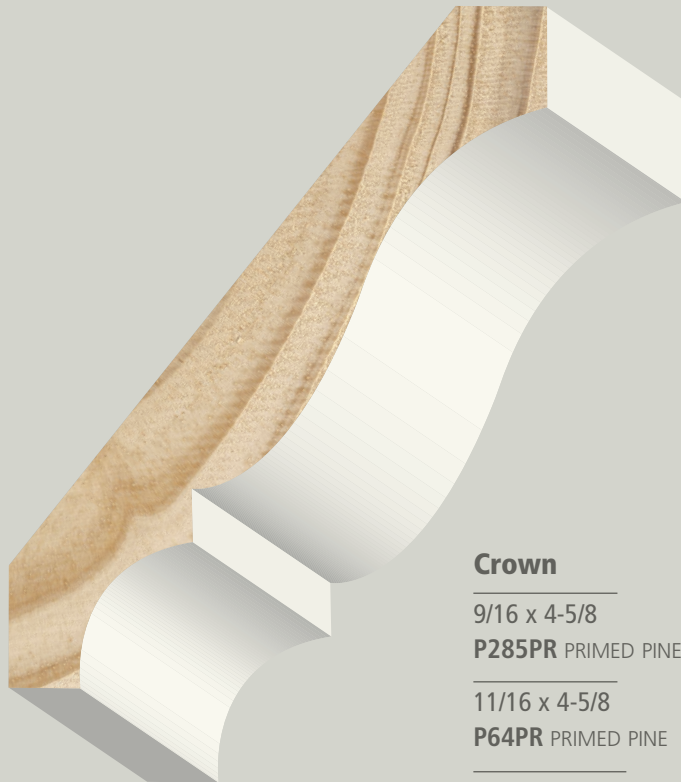

Crown

9/16 x 4-5/8

P285PR PRIMED PINE

11/16 x 4-5/8

P64PR PRIMED PINE

Also available in:

1-5/8, 2-1/4, 2-3/4, 3-1/4, 3-5/8, 5-1/4

4-5/8" to 4-15/16" Crown

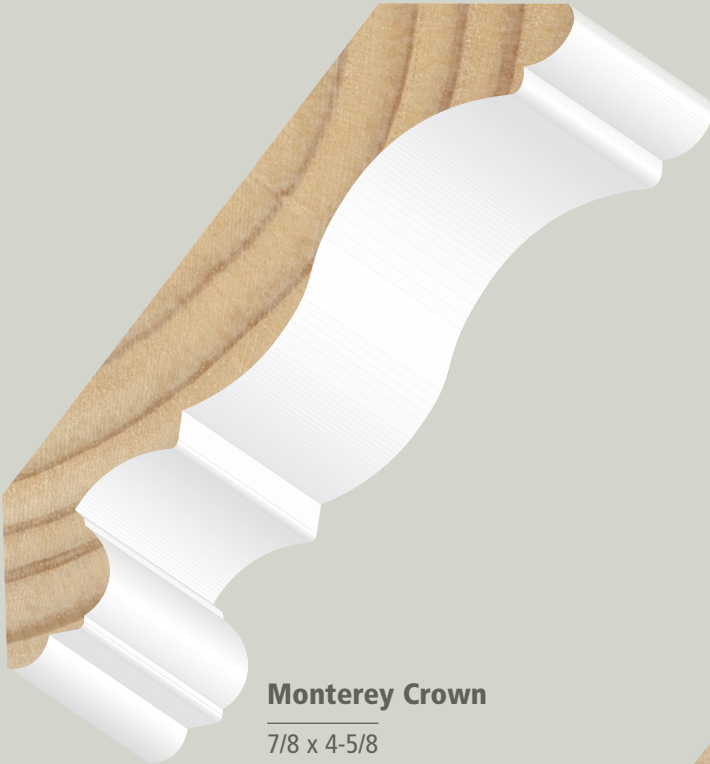

Monterey Crown

7/8 x 4-5/8

P869PPR PREMIUM PRIMED PINE

Also available in:
6-1/2

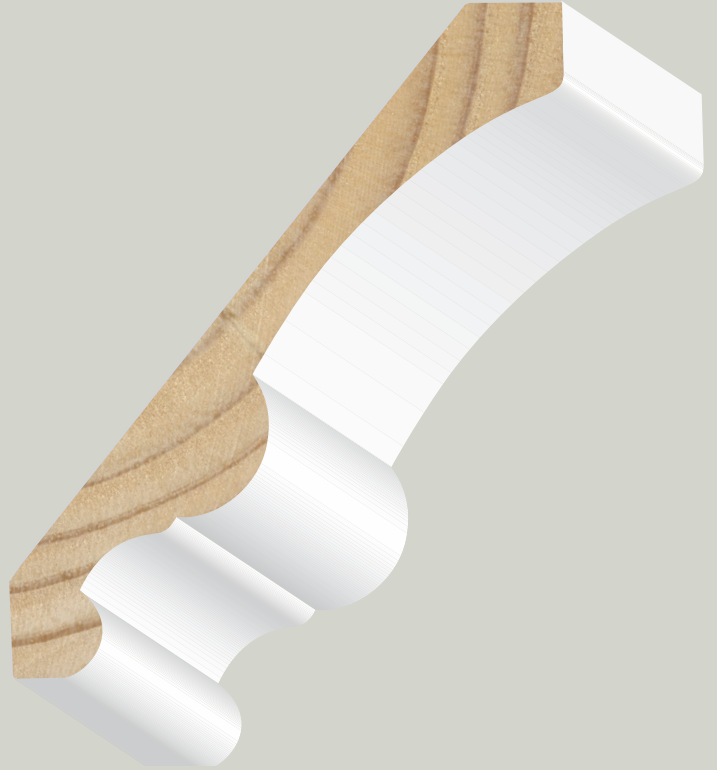

Single Bead Crown

11/16 x 4-5/8

P866PPR PREMIUM PRIMED PINE

Also available in:
3-1/4, 6-1/2



Double Bead Crown

7/8 x 4-15/16

P011PR PRIMED PINE

Also available in:
3-7/16, 7-3/16

5-1/4" Crown

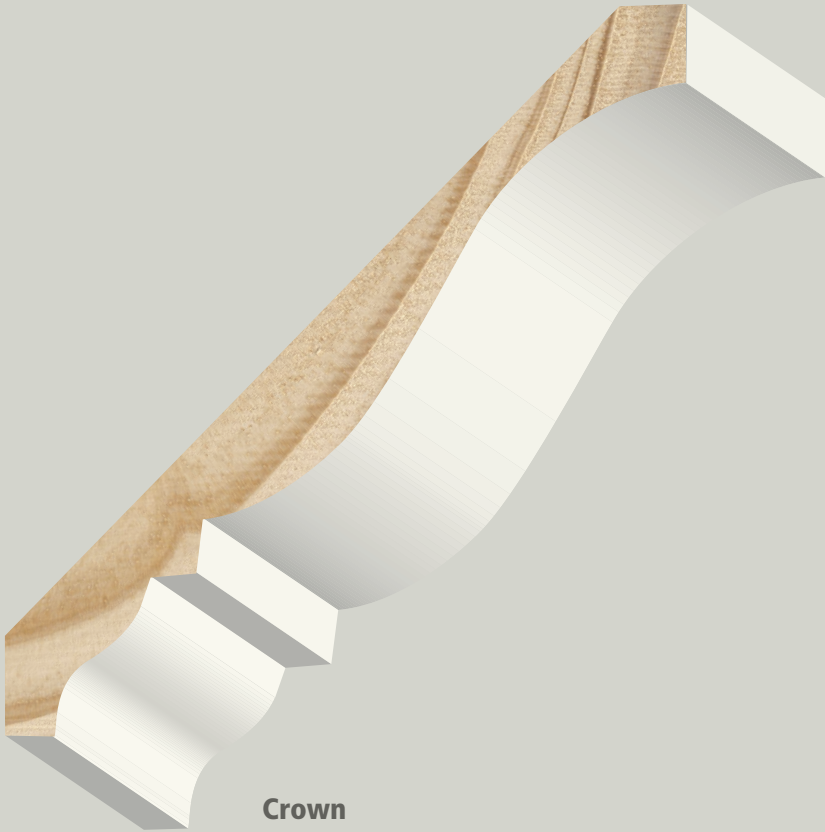

Crown

9/16 x 5-1/4

P494PR PRIMED PINE

Also available in:

4-1/4, 6-3/8



Craftsman Crown

3/4 x 5-1/4

P862PPR PREMIUM PRIMED PINE

Also available in:

2-3/8, 4"

5-1/4" to 6" Crown

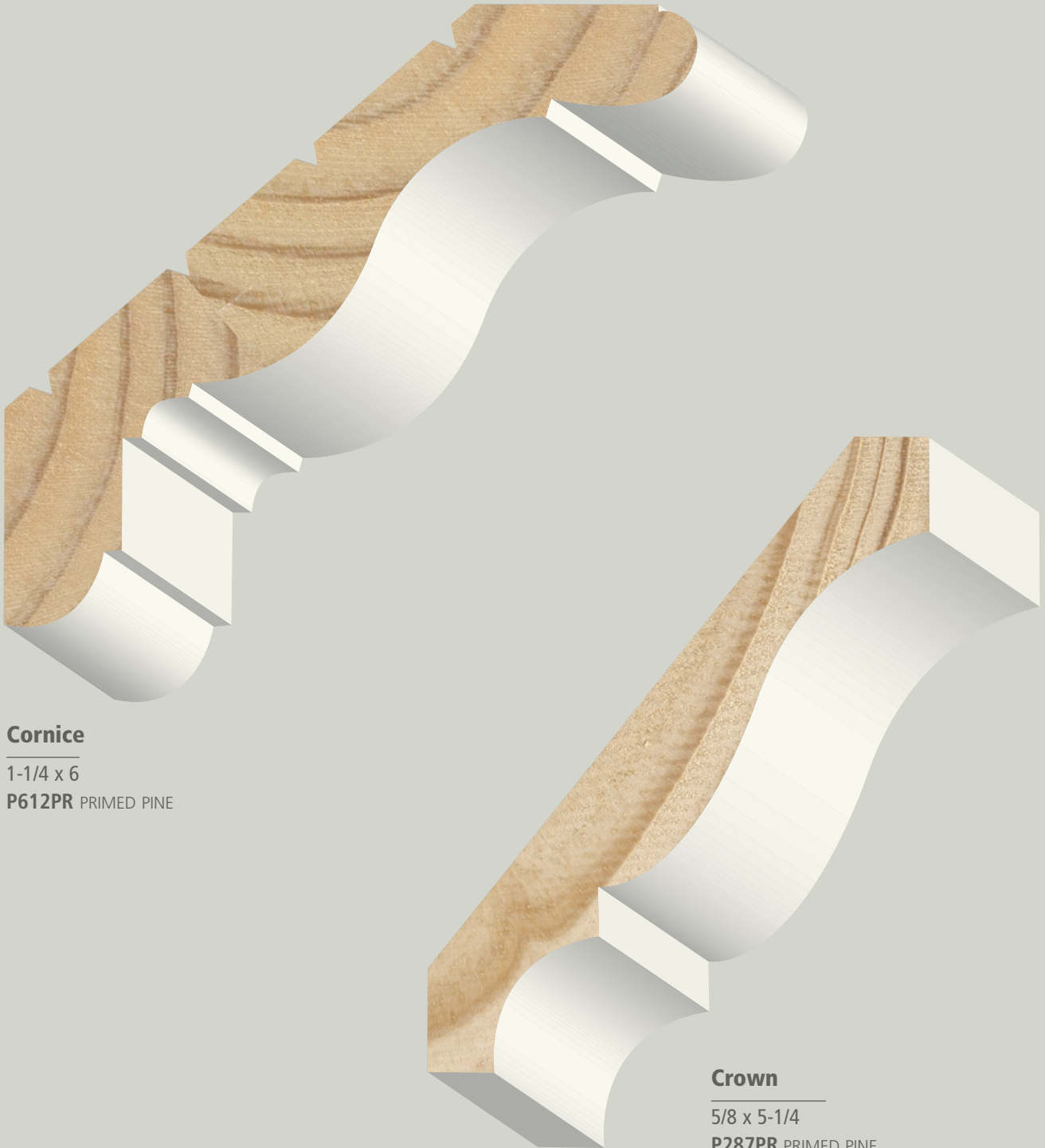

Cornice

1-1/4 x 6

P612PR PRIMED PINE

Crown

5/8 x 5-1/4

P287PR PRIMED PINE

11/16x 5-1/4

P65PR PRIMED PINE

Also available in:

1-5/8, 2-1/4, 2-3/4, 3-1/4, 3-5/8, 4-5/8

6-3/8" to 6-1/2" Crown

PRIMED PINE



Crown

7/8 x 6-3/8

P017PR PRIMED PINE

Also available in:
4-1/4, 5-1/4



Monterey Crown

1-1/4 x 6-1/2

P871PPR PREMIUM PRIMED PINE

Also available in:
4-5/8

6-1/2" to 7-3/16" Crown



Single Bead Crown

7/8 x 6-1/2

P867PPR PREMIUM PRIMED PINE

Also available in:

3-1/4, 4-5/8

Double Bead Crown

1-1/8 x 7-3/16

P012PR PRIMED PINE

Also available in:

3-7/16, 4-15/16

Stops, Caps & Trim



Cap Mould

11/16 x 2

P231PR PRIMED PINE



Colonial Base Cap

11/16 x 2-3/8

P020PR PRIMED PINE



Victorian Base Cap

11/16 x 2-7/16

P021PR PRIMED PINE



Cap

1-3/16 x 2-3/16

P023PR PRIMED PINE

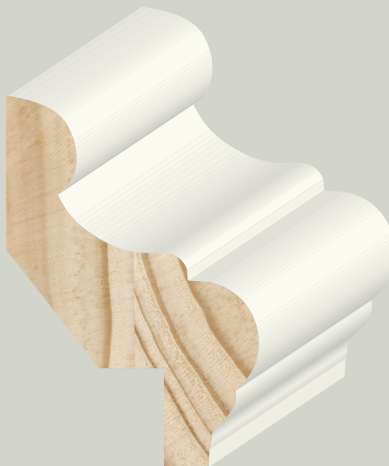

Coronado-Wainscot Cap

3/4 x 2-1/8

P379PR PRIMED PINE



Coronado Cap

11/16 x 1-3/8

P384PR PRIMED PINE

Stops, Caps & Trim



Back Band

1-3/8 x 1-1/16

P022PR PRIMED PINE



Back Band

3/4 x 1"

P383PR PRIMED PINE

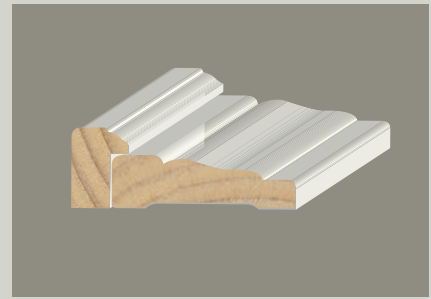

Back Band Use:

Apply Back Bands to new or existing moulding installations to enhance and build up the wall treatment.

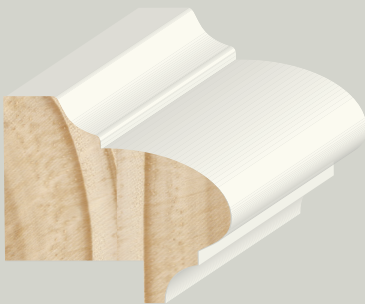

Panel Cap

1-7/32 x 1-1/8

P030PR PRIMED PINE



Bead & Cove Cap

1-3/4 x 1-3/4

P025PR PRIMED PINE

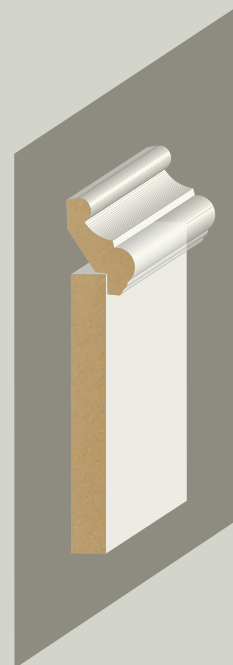

Caps Use:

Use caps over paneling, or wall boards to trim out and build up the wall treatment.

Stops, Caps & Trim



R.E. Stop

7/16 x 1-1/4

P349PR PRIMED PINE ⚙️

P349FJ RAW FJ PINE ⚙️



R.E. Stop

7/16 x 1-3/8

P350PR PRIMED PINE ⚙️

P350FJ RAW FJ PINE ⚙️



Colonial Stop

7/16 x 1-3/8

P359PR PRIMED PINE

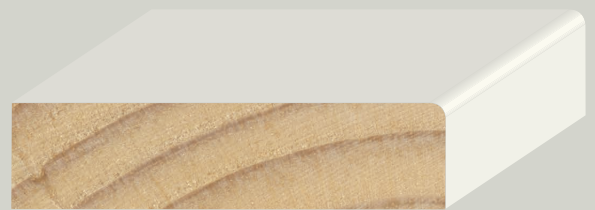

Garage Stop

9/16 x 2-1/4

P110PR PRIMED PINE

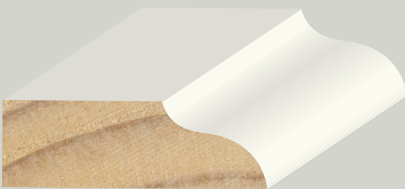

O.G. Stop

7/16 x 1-3/8

P358PR PRIMED PINE



Howe Stop

5/8 x 1-5/8

P353PR PRIMED PINE

Stops, Caps & Trim



Base Shoe

7/16 x 11/16

P229PR PRIMED PINE



Cove

3/4 x 3/4

P274PR PRIMED PINE

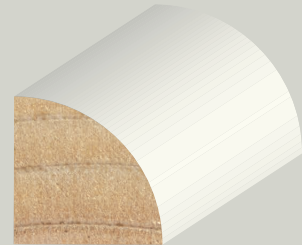

Quarter Round

3/4 x 3/4

P332PR PRIMED PINE

Shelf Mouldings



Rab Hookstrip

11/16 x 4-1/2

P306FJ RAW FJ PINE



Cleat

9/16 x 1-1/2

P343FJ RAW FJ PINE

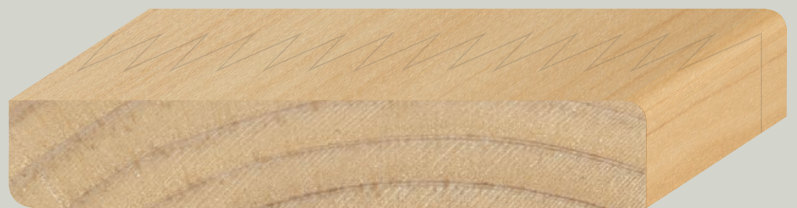

Hook Strip

9/16 x 3-1/4

P305FJ RAW FJ PINE

Stops, Caps & Trim



Craftsman Cap/Picture Mould

13/16 x 2-5/8

P872PPR PREMIUM PRIMED PINE



Picture Mould

11/16 x 1-3/4

P322PR PRIMED PINE



Bead & Cove Nosing

1-1/4 x 1-3/4

P024PR PRIMED PINE



Nosing

1-1/8 x 1-7/16

P018PR PRIMED PINE



Stops, Caps & Trim



Header Cap

1-1/2 x 2-1/2

P876PPR PREMIUM PRIMED PINE

P-876PPR

P-5435PPR

P-895PR

P-847PPR



Craftsman Build-up

A classic Craftsman door casing and header build-up.

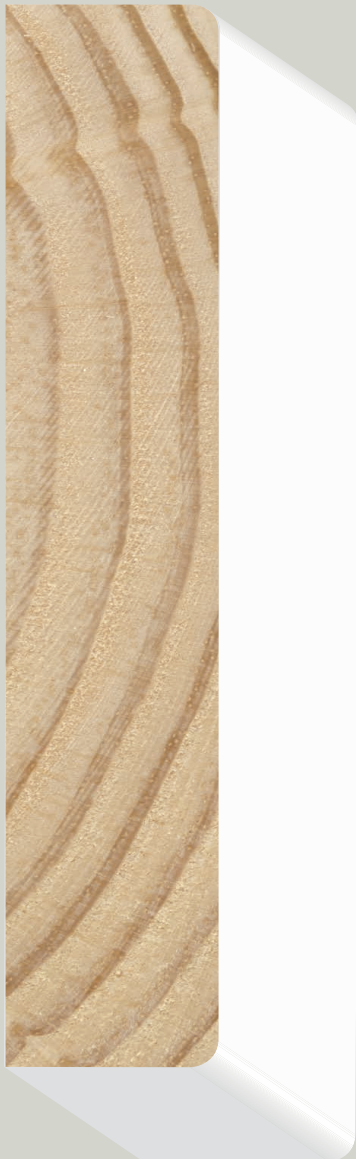

Bead Mold/Fillet

7/16 x 1-1/4

P895PR PRIMED PINE

S4S-E2E Headers

1-1/16 x 3-1/2

P5435PPR PREMIUM PRIMED PINE

1-1/16 x 5-1/2

P5455PPR PREMIUM PRIMED PINE

1-1/16 x 7-1/4

P54725PPR PREMIUM PRIMED PINE



Apron

5/8 x 2-1/4

P892PPR PREMIUM PRIMED PINE

Stops, Caps & Trim



Brick Mould

1-1/4 x 2

P381PR PRIMED PINE



Brick Mould w/Key

1-1/4 x 2

P381PRKEY PRIMED PINE



Reversible T&G Wainscot

1/2 x 3-1/4

P890PPR PREMIUM PRIMED PINE

Shiplap & T&G V-Groove Series

(Shown Here at 60% Actual Size)

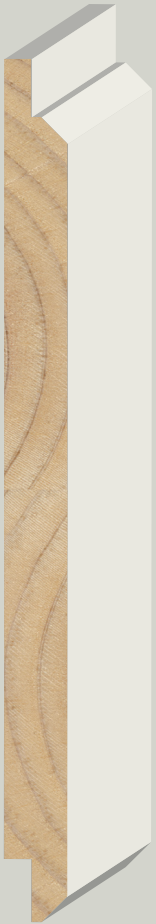

Interior V-Rustic

5/8 x 7-1/2

P1x8PR794 PRIMED PINE

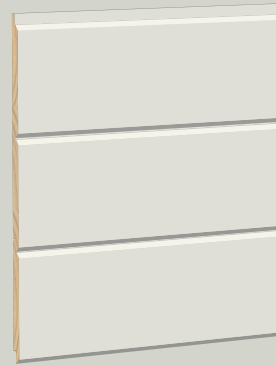
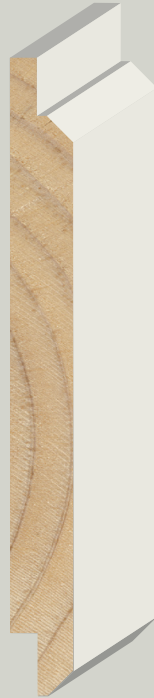

Interior V-Rustic

5/8 x 5-1/2

P1x6PR793 PRIMED PINE

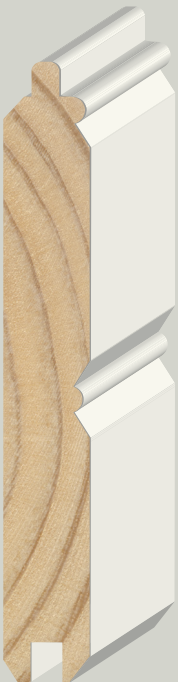

Beaded T&G w/ V-Groove Edges

23/32 x 5-1/2

043220 PRIMED PINE

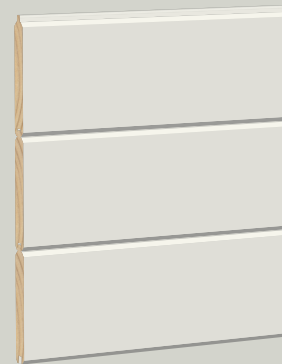

Smooth T&G w/ V-Groove Edges

23/32 x 5-1/2

043230 PRIMED PINE

S4S Boards

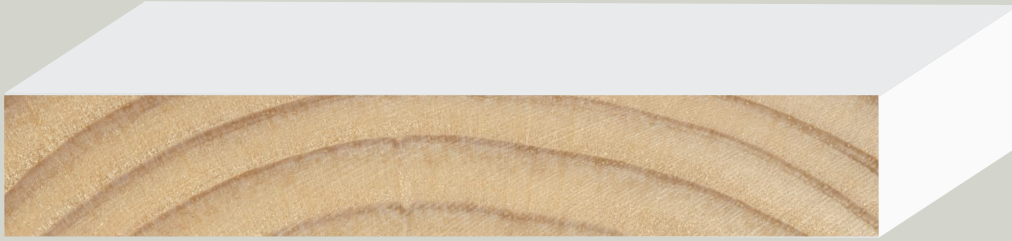

S4S Boards (Nominal Sizes. Please see website for actual dimensions)

Size:	Primed Pine
1x2	P362PR
1x3	P364PR
1x4	P366PR
1x5	P1x5PR
1x6	P1x6PR
1x8	P1x8PR
1x10	P1x10PR
1x12	P1x12PR
5/4x4	P5/4x4PR
5/4x6	P5/4x6PR
5/4x8	P5/4x8PR
5/4x12	P5/4x12PR



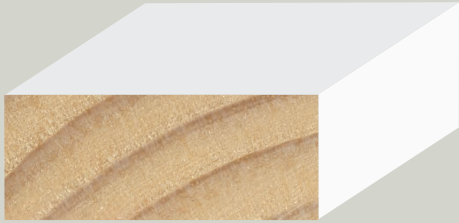

S4S Trim

3/4 x 1-5/8

P362PR PRIMED PINE

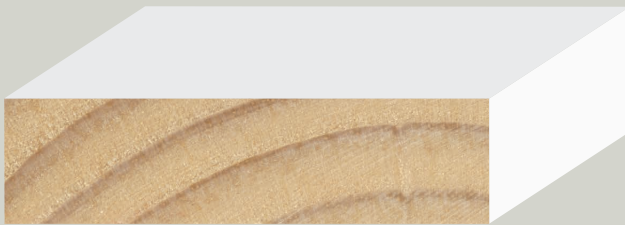

S4S Trim

3/4 x 2-1/2

P364PR PRIMED PINE

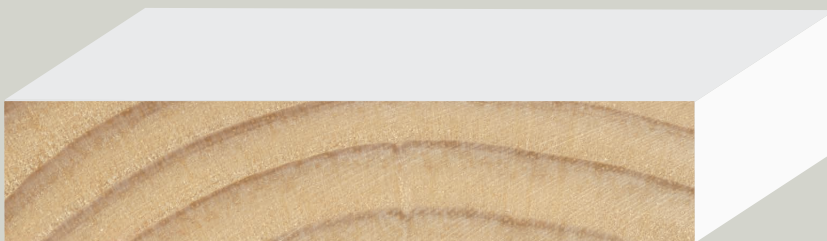

S4S Trim

3/4 x 3-1/2

P366PR PRIMED PINE

Jamb and Framestock

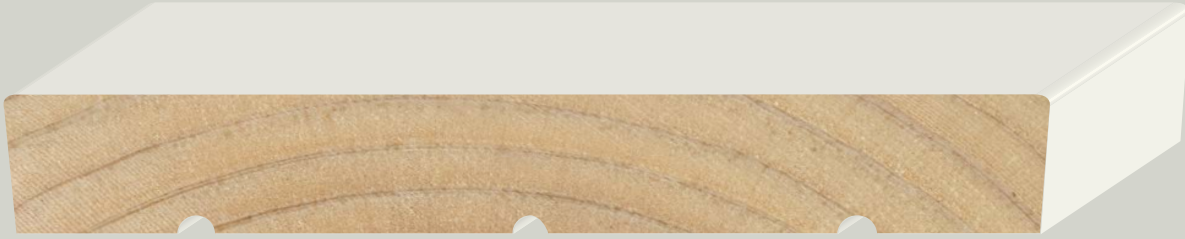

Jambstock (Please see website for additional dimensions)

Size:	Species:	Lineal:	Pairs:	8' Pairs:
4-9/16"	PRIMED PINE	P308PR	PJ308PRP	PJ308PR-96
"	RAW FJ PINE	P308FJ	PJ308FJP	PJ308FJ-96
4-13/16"	PRIMED PINE	P309PR	PJ309PRP	PJ309PR-96
"	RAW FJ PINE	P309FJ	PJ309FJP	PJ309FJ-96
5-1/4"	PRIMED PINE	P310PR	PJ310PRP	PJ310PR-96
"	RAW FJ PINE	P310FJ	PJ310FJP	PJ310FJ-96
6-1/2"	PRIMED PINE	N/A	PJ311PRP	N/A
"	RAW FJ PINE	N/A	PJ311FJP	N/A
7-1/4"	PRIMED PINE	P313PR	PJ312PRP	PJ312PR-96
"	RAW FJ PINE	N/A	PJ312FJP	PJ312FJ-96

INTERIOR JAMB SPECIFICATIONS:

81" below dado. No lug. Dado depth 5/16". Heads cut 5/8" over opening.

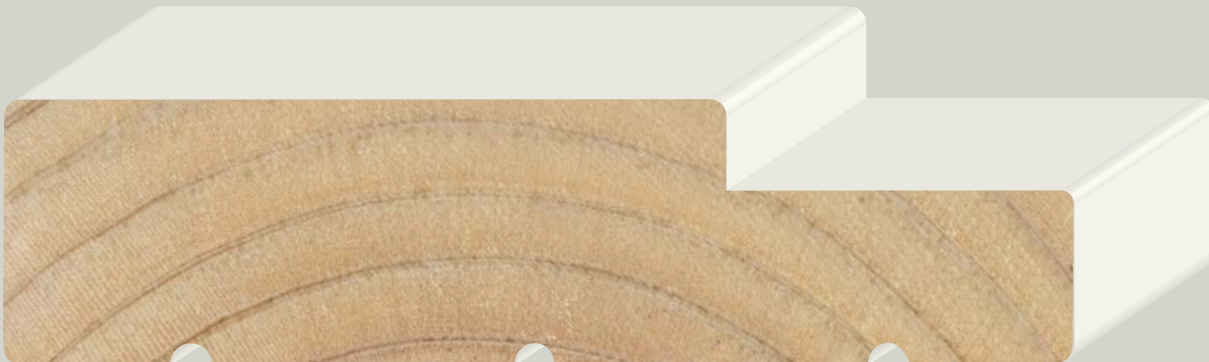

Exterior Frame Stock (Please see website for additional dimensions)

Size:	Rabbet:	Species:	Lineal:	Pairs:	8' Pairs:
4-5/8"	1/2 x 1-13/16	PRIMED PINE	N/A	PF806PRP	PF808PRP
"	1/2 x 1-13/16	RAW FJ PINE	N/A	PF806FJP	N/A
5-1/4"	1/2 x 1-13/16	PRIMED PINE	P816PR	PF816PRP	N/A
"	1/2 x 1-13/16	RAW FJ PINE	P816FJ	PF816FJP	N/A
6-5/8"	1/2 x 1-13/16	PRIMED PINE	N/A	PF721PRP	PF721PR8
"	1/2 x 1-13/16	RAW FJ PINE	N/A	PF721FJP	N/A
7-1/4"	1/2 x 1-13/16	PRIMED PINE	P726PR	PF726PRP	PF728PRP
"	1/2 x 1-13/16	RAW FJ PINE	P726FJ	PF726FJP	N/A

EXTERIOR FRAME SPECIFICATIONS:

82-1/2" below dado. Single end dado 1-1/4" for head. No lug. Eased face corners. No sill dado. Heads rough cut 37".

Jamb and Framestock



Kerfed Exterior Frame Stock (Please see website for additional dimensions)

Size:	Rabbet:	Species:	Lineal:	Pairs:	8' Pairs:
4-1/8	1/2 x 2-3/16	PRIMED PINE	N/A	PF802PRKP	PF802PRK8
"	1/2 x 2-3/16	RAW FJ PINE	N/A	PF802FJKP	N/A
4-5/8	1/2 x 2-3/16	PRIMED PINE	N/A	PF806PRKP	PF808PRKP
"	1/2 x 2-3/16	RAW FJ PINE	N/A	PF806FJKP	PF808FJKP
5-1/4	1/2 x 2-3/16	PRIMED PINE	P816PRK	PF816PRKP	PF818PRKP
"	1/2 x 2-3/16	PRIMED PINE (FIRE RATED)	N/A	PF717PRS (SET)	N/A
"	1/2 x 2-3/16	RAW FJ PINE	P816FJK	PF816FJKP	PF818FJKP
6-5/8	1/2 x 2-3/16	PRIMED PINE	N/A	PF721PRKP	N/A
"	1/2 x 2-3/16	RAW FJ PINE	N/A	PF721FJKP	N/A
7-1/4	1/2 x 2-3/16	PRIMED PINE	P726PRK	PF726PRKP	PF728PRKP
"	1/2 x 2-3/16	PRIMED PINE (FIRE RATED)	N/A	PF737PRS (SET)	N/A

EXTERIOR KERFED FRAME SPECIFICATIONS:

Single end dado 1-1/4" for head. No lug. Eased face corners. No sill dado. 82-1/2" below dado, single rabbeted 1/2" x 2-3/16", kerfed for weatherstrip 1/8" x 1/2" with a 1/32" offset from the face of the rabbet. Fire rated products have a rating of 20 minutes.

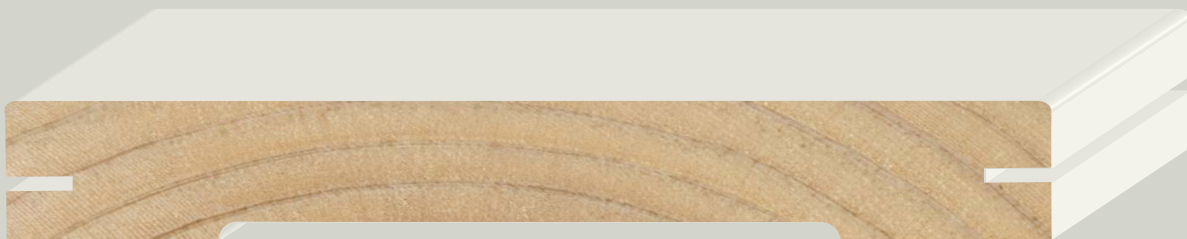

Interior Kerfed Jambstock

Size:	Species:	Lineal:	Pairs:	8' Pairs:
3-9/16"	PRIMED PINE	N/A	N/A	PJ-306PRK8

INTERIOR JAMB SPECIFICATIONS:

81" below dado. No lug. Dado depth 5/16". Heads cut 5/8" over opening.

Note: Jambs and frames are available in a wide variety of sizes, wood species, and pre-cut 7' or 8' lengths. Please ask your sales representative for item numbers and availability.

Framestock and Stool



Exterior Reversible Door Frame

Size:	Rabbets	Species:	Pairs:
4-5/8	1/2x1-7/16 & 1/2x1-13/16	RAW FJ PINE	PF305FJP
5-1/4	1/2x1-7/16 & 1/2x1-13/16	RAW FJ PINE	PF315FJP
6-5/8	1/2x1-7/16 & 1/2x1-13/16	RAW FJ PINE	PF722FJP
7-1/4	1/2x1-7/16 & 1/2x1-13/16	RAW FJ PINE	PF727FJP
"	1/2x1-7/16 & 1/2x1-13/16	PRIMED PINE	PF727PRP

EXTERIOR FRAME SPECIFICATIONS:

82-1/2" below dado. Single end dado 1-1/4" for head. No lug. Eased face corners. No sill dado. Heads rough cut 37".

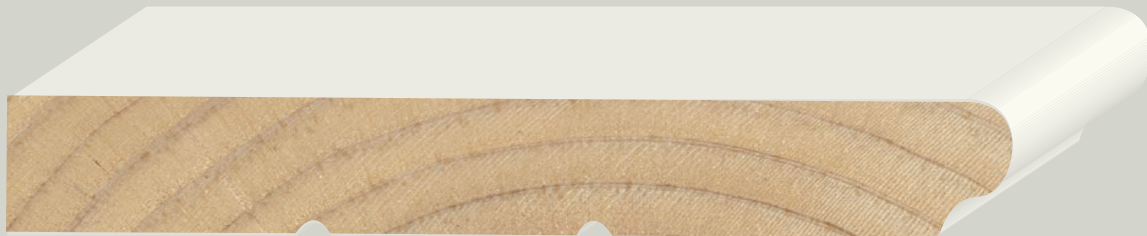

Window Sash Stool (Lineal)

Size:		
1-1/16 x 2	PRIMED PINE	P019PR
11/16 x 4-11/16	PRIMED PINE	P373PR
11/16 x 5-1/4	PRIMED PINE	P376PR
"	RAW FJ PINE	P376FJ
11/16 x 7-1/4	PRIMED PINE	P377PR
"	RAW FJ PINE	P377FJ

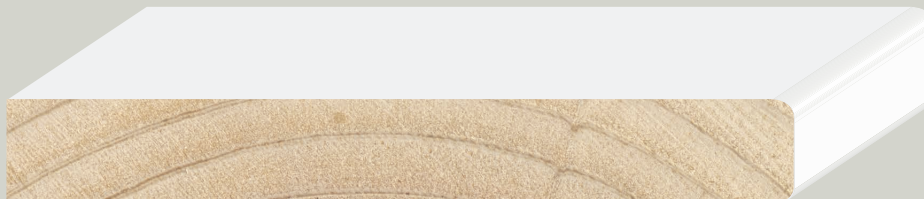

Craftsman Stool

11/16 x 5-1/2

P877PPR PREMIUM PRIMED PINE

Note: Jambs and frames are available in a wide variety of sizes, wood species, and pre-cut 7' or 8' lengths. Please ask your sales representative for item numbers and availability.



EXTERIOR MOULDING

Crowns & Trim

Treated Exterior Grade Moulding

About Advantage Plus LOSP Mouldings



Advantage Plus Exterior grade mouldings have the same features and benefits as Advantage Plus siding and trim boards. LOSP (Light organic solvent preservatives) are used to treat the wood making them safer to use and handle than other treated products. Finish with two coats of quality 100% acrylic paint. Note: Some patterns are also available in Western Red Cedar or Redwood.

When pre-primed material is cut during field application, the cut end must be field primed and sealed prior to installation. Nail holes should also be filled and preserved immediately after installation to prevent the uptake of moisture. Factory pre-primed surfaces should be painted within 30 days of installation

Use two topcoats of a top-quality acrylic latex paint. Acrylic latex paints remain flexible with age, thus stretching and shrinking with the wood and allowing some passage of water vapor. Finish coats or topcoats can be applied to broad surfaces by roller or spray.



Insect and Rot Resistant



Fingerjoint Strength



Double Coat



Non Corrosive



Renewable Resource



EPA (USA) Approved



Rating



30 Year Warranty

Exterior Crown

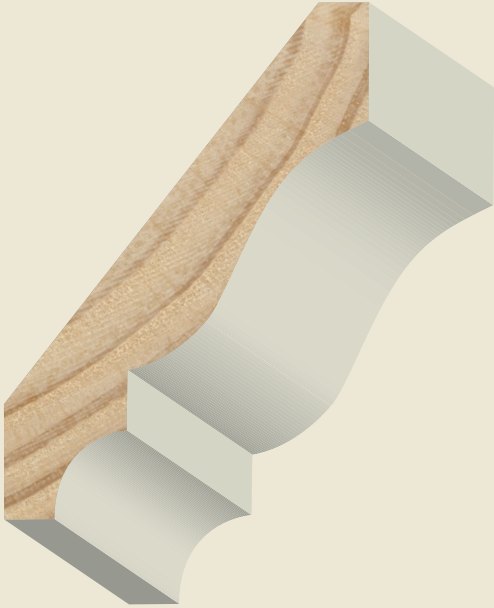

Colonial Crown

5/8 x 3-5/8

EX286PR TREATED PRIMED PINE

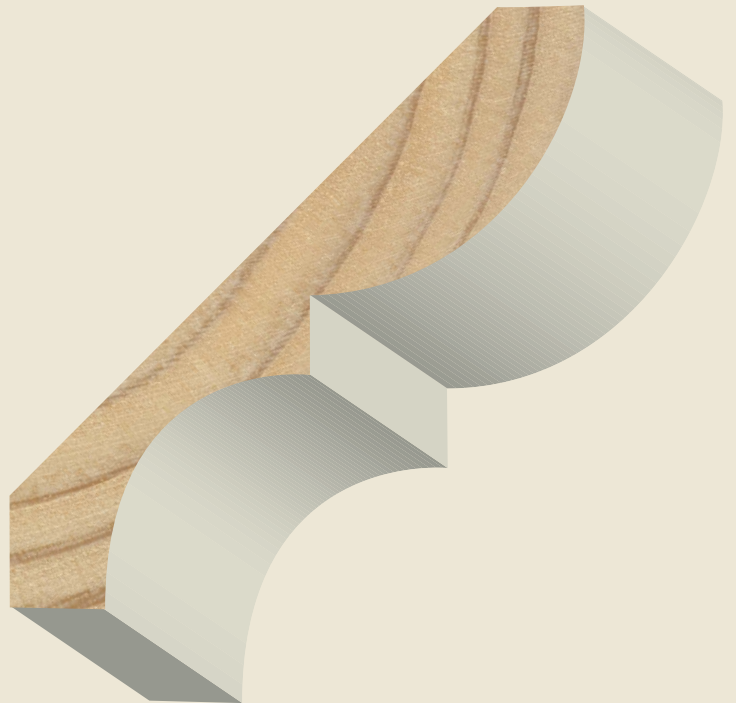

Bed Mould

3/4 x 4-5/16

EX639PR TREATED PRIMED PINE

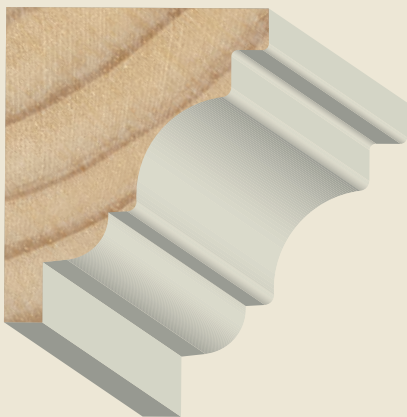

Pediment Crown

1-1/4 x 1-1/2

EX607PR TREATED PRIMED PINE

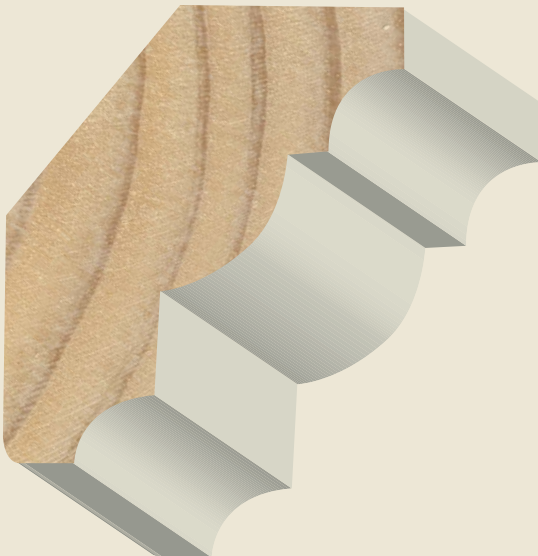

Gutter Mould

1-3/8 x 3-5/16

EX638PR TREATED PRIMED PINE

Decorative Moulding

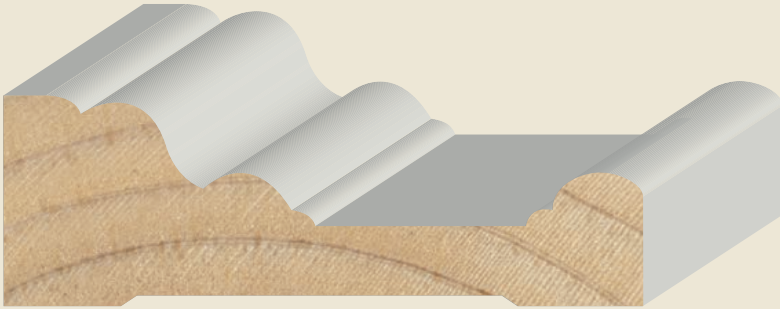

Howe Casing

1-1/16 x 3-1/4

EX387PR TREATED PRIMED PINE

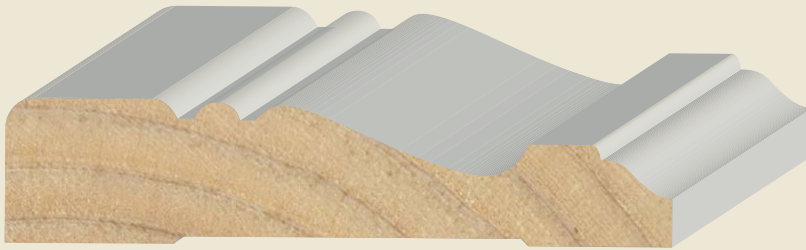

Carolina Casing

1 1/16 x 3-1/4

EX388PR TREATED PRIMED PINE



Bead & Cove Nosing

1-1/4 x 1-3/4

EX024PR TREATED PRIMED PINE



Tahoe Architrave

1-3/16 x 4-1/4

EX1400PR TREATED PRIMED PINE

Decorative Moulding

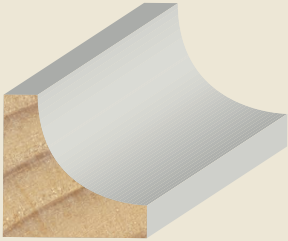

Cove

11/16 x 11/16

C606 CEDAR (STAIN GRADE OPTION)

CEDAR

3/4 x 3/4

EX606PR TREATED PRIMED PINE

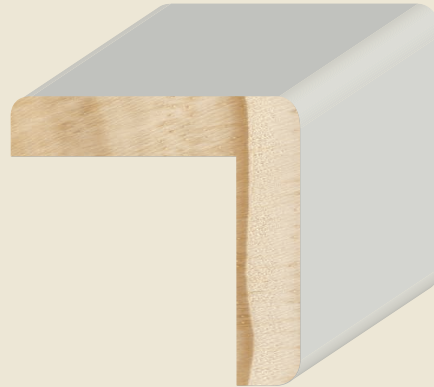

Corner Guard

1-1/2 x 1-1/2

EX604PR TREATED PRIMED PINE

C604 CEDAR (STAIN GRADE OPTION)

CEDAR

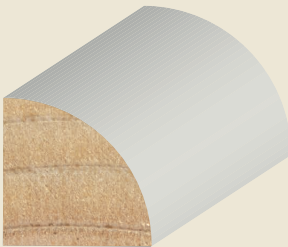

Quarter Round

11/16 x 11/16

C614 CEDAR (STAIN GRADE OPTION)

CEDAR

3/4 x 3/4

EX614PR TREATED PRIMED PINE

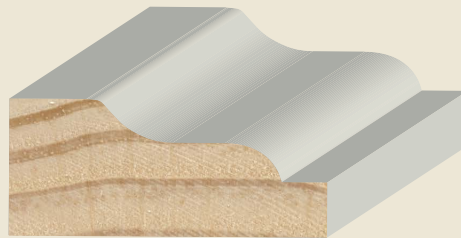

Shingle Mould

11/16 x 1-5/8

EX616PR TREATED PRIMED PINE

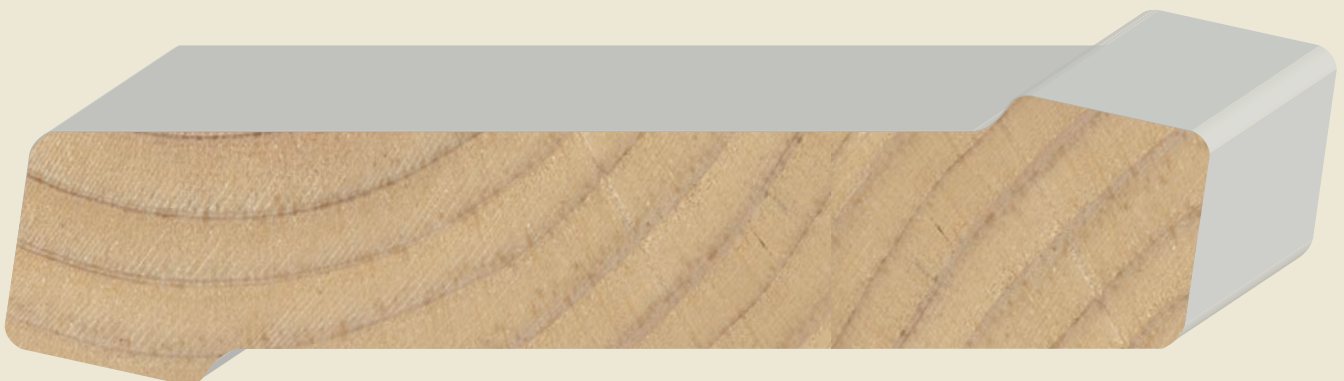

Reversible Sill

2 x 8

EX640PR TREATED PRIMED PINE

Utility Moulding



Watertable w/Lip

1-5/16 x 1-7/8

EX630PR TREATED PRIMED PINE

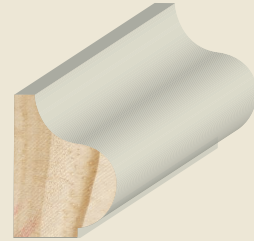

Base Cap

9/16 x 3/4

EX224PR TREATED PRIMED PINE

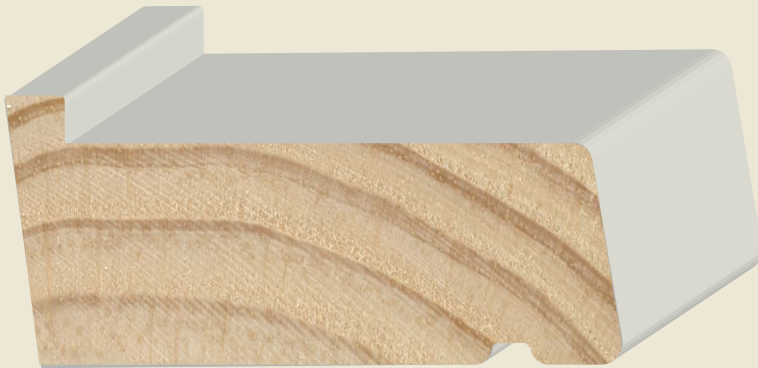

Watertable

1-7/16 x 3-1/4

EX634PR TREATED PRIMED PINE

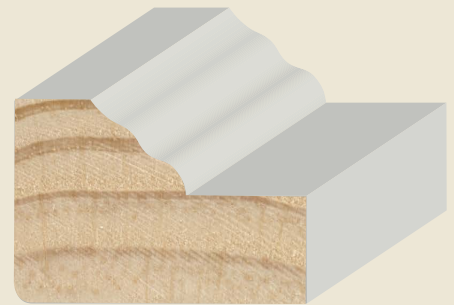

Brick Mould

1-1/16 x 1-3/8

EX619PR TREATED PRIMED PINE



Brick Mould

1-1/4 x 2

EX381PR TREATED PRIMED PINE



Utility Moulding



Stucco Mould

1 x 2-1/2

EX629PR TREATED PRIMED PINE



Stucco Mould

13/16 x 1-1/2

EX618PR TREATED PRIMED PINE ⚙



3-Step Stucco

11/16 x 1-15/16

EX627PR TREATED PRIMED PINE



Mushroom Handrail

1-7/16 x 1-15/16

C501 CEDAR



Flat Bottom Handrail

1-1/2 x 1-11/16

C505 CEDAR

⚙ Available in Cut to Length)

Utility Moulding



Batten S1S2E

5/16 x 2-1/2

C603 CEDAR



R.E. Stop

7/16 x 1-3/8

C625 CEDAR



Lattice

5/16 x 1-3/8

C610 CEDAR

5/16 x 1-5/8

C612 CEDAR

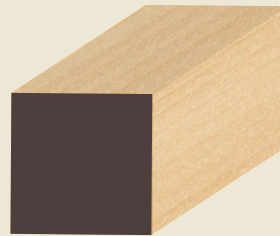

Square

11/16 x 11/16

C626 CEDAR



**Wiggly Mould for
Fiberglass Panels**

3/4 x 1-3/8 x 8'

R632 TREATED STAINED WHITEWOOD



STAIN GRADE MOULDING

**Floor, Ceiling, Wall, Window
and Door, Trim, Caps & Stops**

Stain Grade Moulding

About Stain Grade Moulding

Stain Grade mouldings are made from solid wood. They can be stained and finished using a variety of methods to reveal rich color and wood grain patterns.

Mouldings in this section are arranged by usage and profile, and several sizes are often listed under each profile. Icons that appear beside each profile indicate availability in various species. Please refer to the section titled Types of Mouldings, Species and Finishes for more information on various species.

Stain grade mouldings are used both in historic homes with vintage decor, and in more contemporary homes to add warmth and a natural feel. Some usage examples shown throughout this catalog combine the use of stain grade mouldings with painted decor for an interesting effect.

Some solid wood mouldings such as corner guards, stops, and trim boards are sometimes painted for use in painted decor, where durability and strength are needed. Such applications include high traffic areas, doorways, and cabinetry.



Pine



Oak



Alder/Knotty Alder



Poplar



Redwood



Cedar

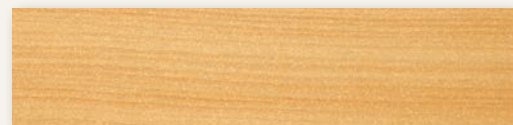

Douglas Fir

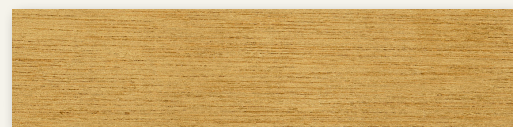

Mahogany

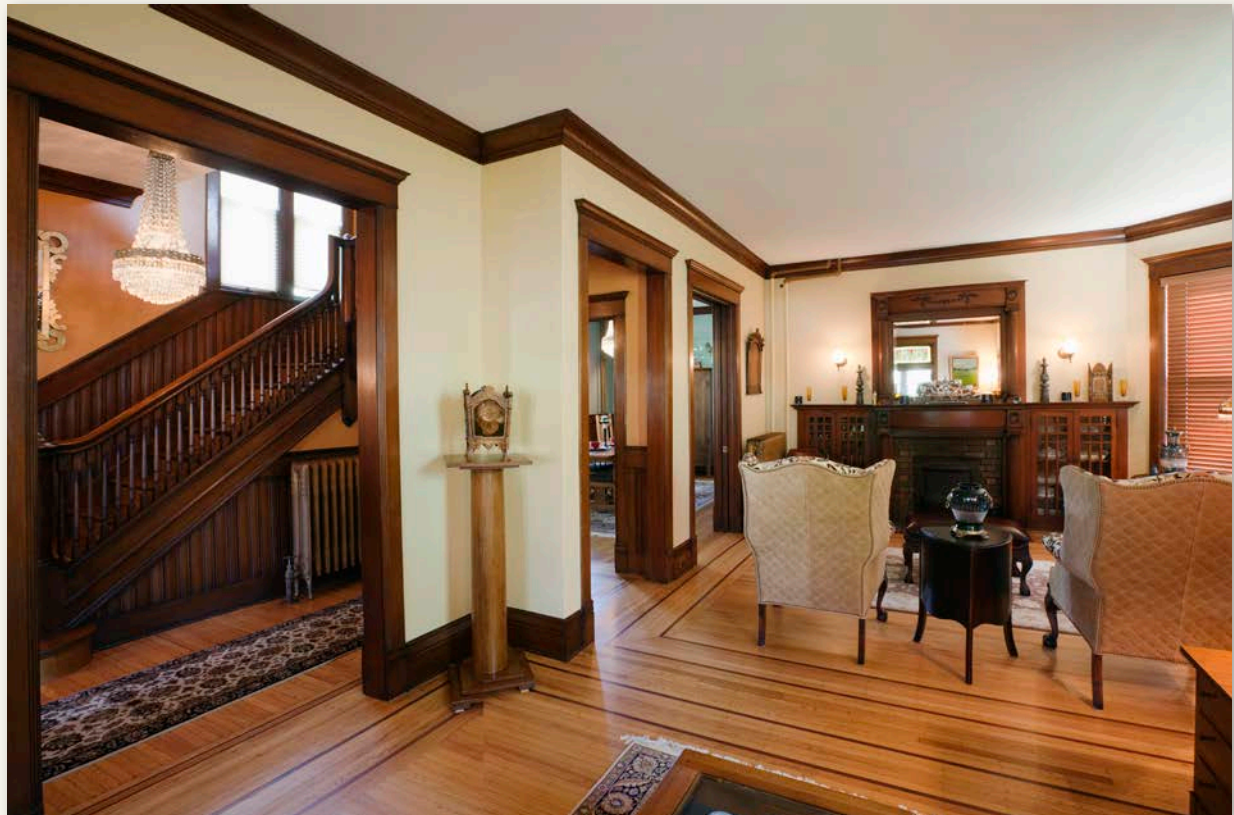

Bases

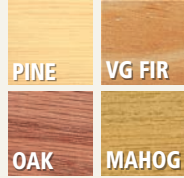

R.E. Reversible Base

- 5/16 x 1-3/4
M902 STAINED MAHOGANY
- 1/2 x 2-1/4
P208 SOLID PINE
- 3/8 x 2-1/4
P212 SOLID PINE
- O212** OAK
- VG212** VG DOUG FIR

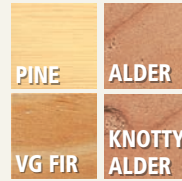

One R.E. Base

- 1/2 x 3-1/2
VG1204 VG DOUG FIR
- 5/8 x 4
ALD205 ALDER
- 1/2 x 4-1/2
VG1205 VG DOUG FIR
- 5/8 x 4-1/2
KALD057 KNOTTY ALDER
- 5/8 x 5
KALD059 KNOTTY ALDER
- 5/8 x 5-1/4
ALD208 ALDER
- 1/2 x 5-1/2
P206 SOLID PINE

(90% of actual size)

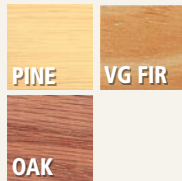

R.E. Reversible Base

- 1/2 x 3-1/4
P210 SOLID PINE
- VG210** VG DOUG FIR
- 3/8 x 3-1/4
P214 SOLID PINE
- O214** OAK



Streamline Base

- 1/2 x 2-1/4
P218 SOLID PINE
- 1/2 x 3-1/4
P220 SOLID PINE

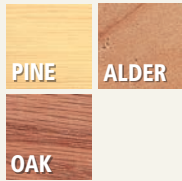

Base Shoe

1/2 x 3/4

P226 SOLID PINE

O226 OAK

ALD226 ALDER



Two R.E.

1 x 5-1/2

VG1398 VG DOUG FIR

Bases

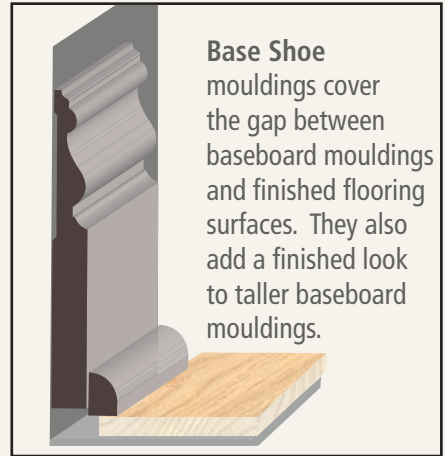

Base Shoe mouldings cover the gap between baseboard mouldings and finished flooring surfaces. They also add a finished look to taller baseboard mouldings.



Bases

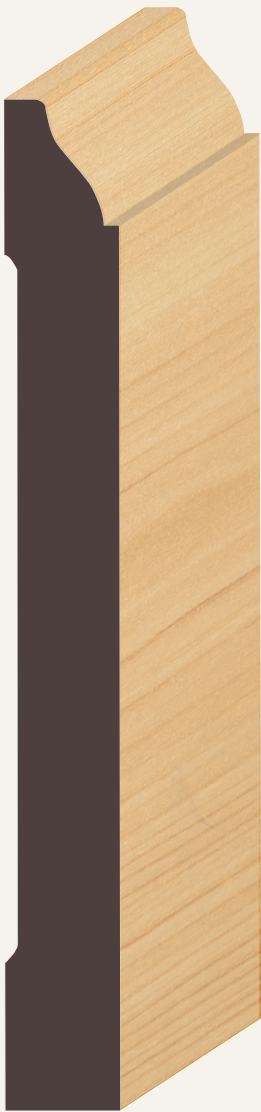

Coronado Base

9/16 x 5-1/4

P223 SOLID PINE

ALD223 ALDER



Coronado Base

9/16 x 3-1/8

O221 OAK

9/16 x 3-1/4

P221 SOLID PINE

ALD221 ALDER

VG221 VG DOUG FIR



Sierra Base

9/16 x 5-1/4

ALD217 ALDER



Tahoe Base

1/2 x 4-1/4

VG1216 VG DOUG FIR

1/2 x 5-1/2

VG1217 VG DOUG FIR



Monterey Base

5/8 x 5-1/4

ALD120 ALDER

Bases



Santa Fe Base

9/16 x 3-1/2
0203S OAK

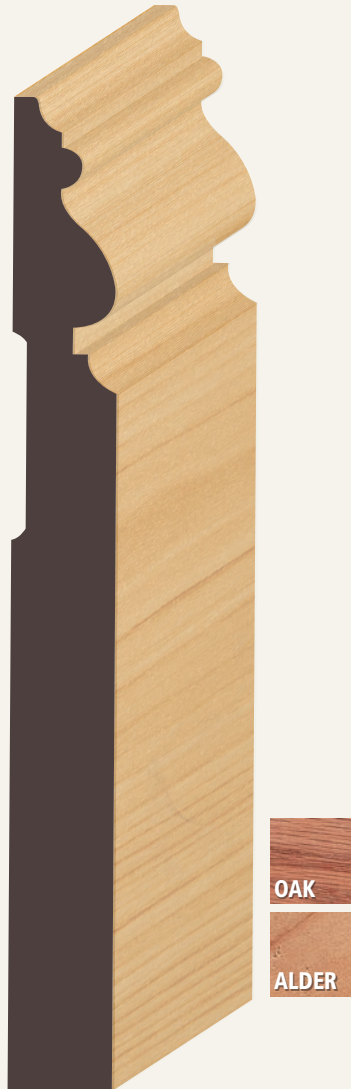

Santa Fe Base

9/16 x 5-1/4
0009 OAK

9/16 x 5-7/16
ALD112 ALDER



Victorian Base

9/16 x 4
ALD83 ALDER



Casings



Round Edge Casing

9/16 x 1-5/8

P232 SOLID PINE



Round Edge Casing

9/16 x 2-1/4

P234 SOLID PINE

VG234 VG DOUG FIR ⚙️

5/8 x 2-1/2

VG1235 VG DOUG FIR

3/4 x 2-1/4

ALD234 ALDER



Round Edge Casing

9/16 x 3-1/4

P236 SOLID PINE

3/4 x 3-1/4

ALD236 ALDER

5/8 x 3-1/2

VG1236 VG DOUG FIR

3/4 x 3-1/2

KALD236 KNOTTY ALDER



Casings



Streamline Casing

5/8 x 1-5/8

P252 SOLID PINE

5/8 x 2-1/4

P254 SOLID PINE

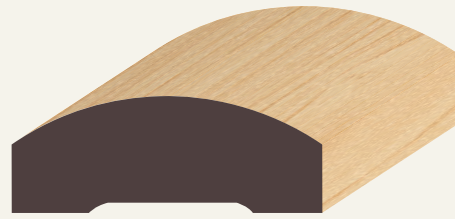

Oval Casing

9/16 x 1-5/8

P244 SOLID PINE

9/16 x 2-1/4

P246 SOLID PINE



Bevel Casing

5/8 x 1-5/8

P256 SOLID PINE ⚙️

O256 OAK



Step Casing

5/8 x 1-5/8

P248 SOLID PINE

5/8 x 2-1/4

P250 SOLID PINE



Bevel Casing

5/8 x 2-1/4

P258 SOLID PINE ⚙️

O258S OAK



Moulded Casing

5/8 x 1-5/8

P238 SOLID PINE

O238 OAK



⚙️ Available in Cut to Length)

Casings



Moulded Casing

5/8 x 2-1/4

P240 SOLID PINE ⚙️

O240 OAK ⚙️

VG240 VG DOUG FIR ⚙️

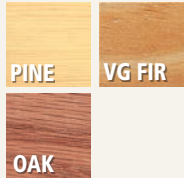

Colonial Casing/356

5/8 x 2-1/4

O239 OAK

11/16 x 2-1/4

P239 SOLID PINE ⚙️

VG239 VG DOUG FIR ⚙️

ALD239 ALDER

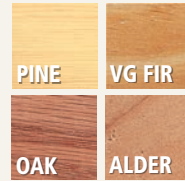

Moulded Casing

5/8 x 3-1/4

P242 SOLID PINE

O242 OAK

VG242 VG DOUG FIR

11/16 x 3-1/4

ALD242 ALDER

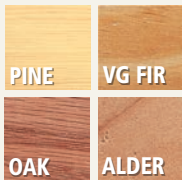

Bay Shore Casing

3/4 x 2-1/2

ALD32 ALDER



Casings



Riviera Casing

1 1/16 x 2-1/2

P385 SOLID PINE

5/8 x 2-1/2

O385 OAK



Victorian Casing

3/4 x 2-1/2

P262S SOLID PINE

O262 OAK

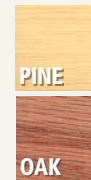

Carolina Casing

1 1/16 x 3-1/2

O388 OAK



49er Casing

1 x 3-1/4

P380 SOLID PINE

O380 OAK

ALD380 ALDER

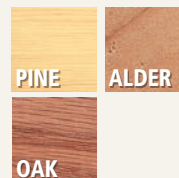

Casings



Lancaster Casing

1-3/16 x 3-3/8
ALD36 ALDER



Tahoe Casing

3/4 x 3-1/2
VG1250 VG DOUG FIR



Santa Fe Casing

1-1/16 x 3-7/16
ALD393 ALDER

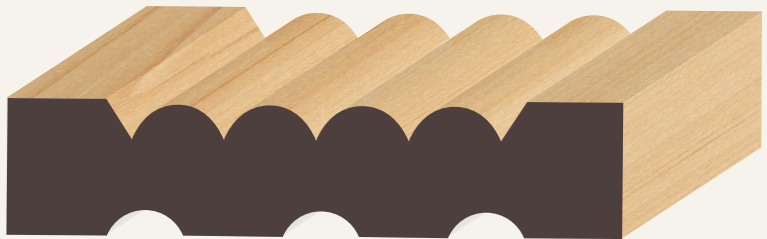

Flute & Reed Casing

11/16 x 3-1/4
O386 OAK
3/4 x 3-3/8
ALD386 ALDER



Chair Rails



Chair Rail OAK

3/4 x 2-1/8
0390 OAK



Chair Rail PINE

9/16 x 2
P-265 SOLID PINE



Chair Rail OAK

5/8 x 2-1/2
0452 OAK

11/16 x 2-1/2
ALD452 ALDER



Bead and Barrel Chair Rail

3/4 x 3
ALD179 ALDER



Coronado Chair Rail/Casing

9/16 x 2-5/8
0382 OAK

5/8 x 2-5/8
P382 SOLID PINE

Crown



Colonial Crown

5/8 x 1-5/8
P282 SOLID PINE
O282 OAK

5/8 x 2-3/4
P284 SOLID PINE



Colonial Crown

3/4 x 7-1/4
ALD106 ALDER

Colonial Crown

3/4 x 3-1/4
ALD286 ALDER

5/8 x 3-1/4
O286 OAK

5/8 x 3-5/8
P286 SOLID PINE

Crown

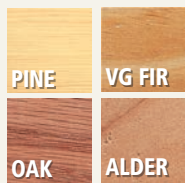

Colonial Crown

3/4 x 4-1/4

ALD285 ALDER

5/8 x 4-1/4

VG1285 VG DOUG FIR

5/8 x 4-5/8

P285 SOLID PINE

O285 OAK

5/8 x 5-1/4

P287 SOLID PINE

VG1065 VG DOUG FIR

3/4 x 5-1/4

ALD65 ALDER



Crown

1/2 x 2-1/4

O491 OAK



Tahoe Crown

3/4 x 4-1/4

VG1035 VG DOUG FIR

Crown



Regal Crown

VG FIR

1-1/8 x 7-3/16

VG1045 VG DOUG FIR

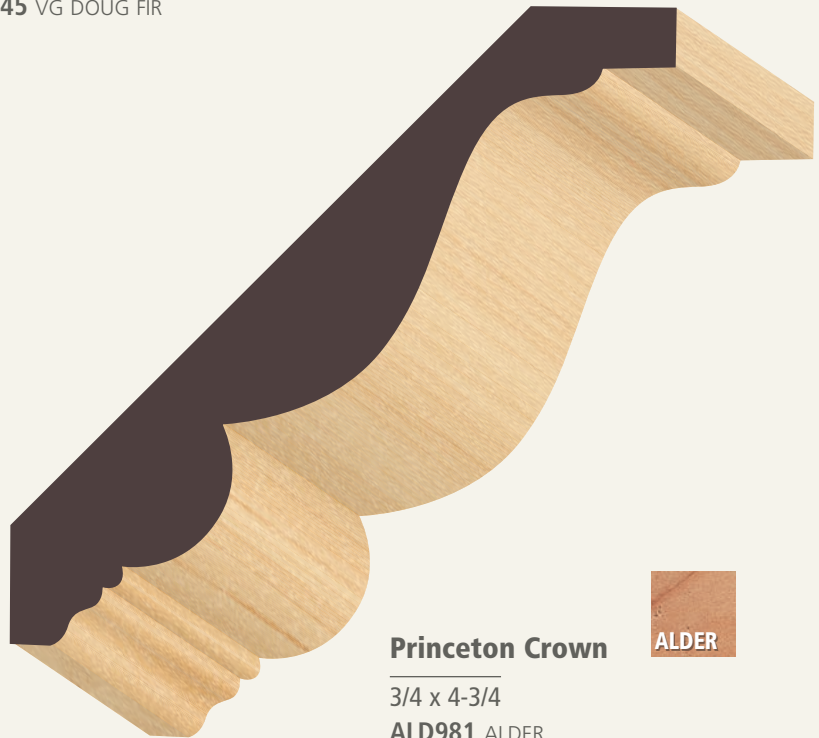

Princeton Crown

ALDER

3/4 x 4-3/4

ALD981 ALDER



Double Bead Crown

1-1/8 x 6-1/2
ALD012 ALDER



ALDER

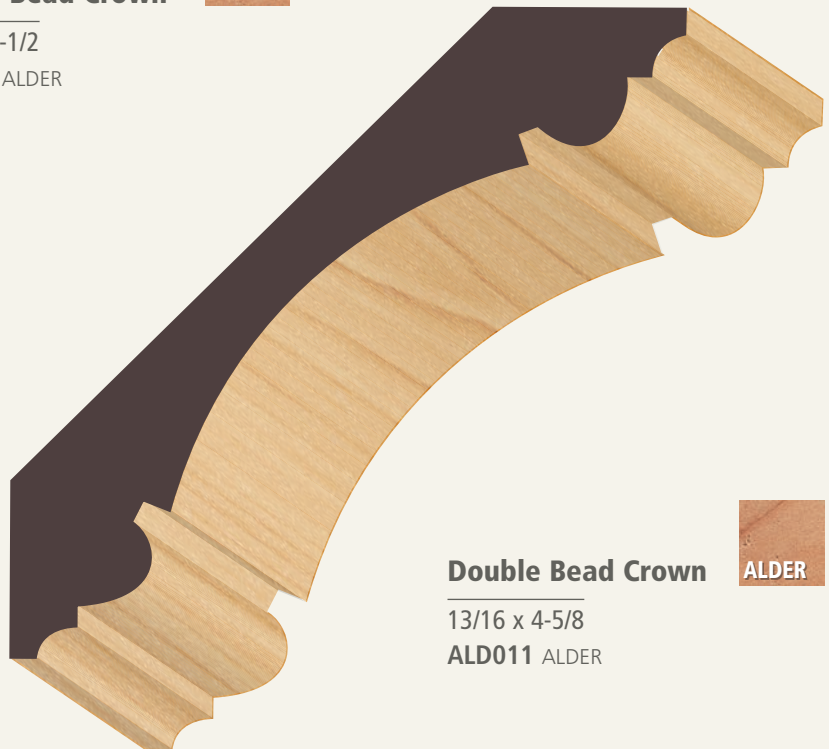

Double Bead Crown

13/16 x 4-5/8
ALD011 ALDER



ALDER

Crown/Pediment

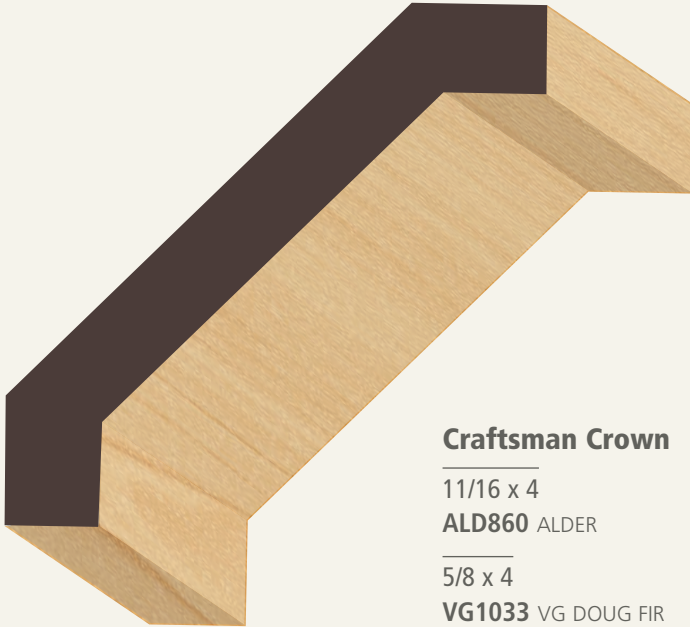

Craftsman Crown

1 1/16 x 4

ALD860 ALDER

5/8 x 4

VG1033 VG DOUG FIR



Tahoe Architrave

1-3/16 x 4-1/4

VG1400 VG DOUG FIR

Headers



**Solid Fir S4S-E4E
Alpine Architrave**



1 x 5-1/2

VG1398 VG DOUG FIR

(90% of actual size)

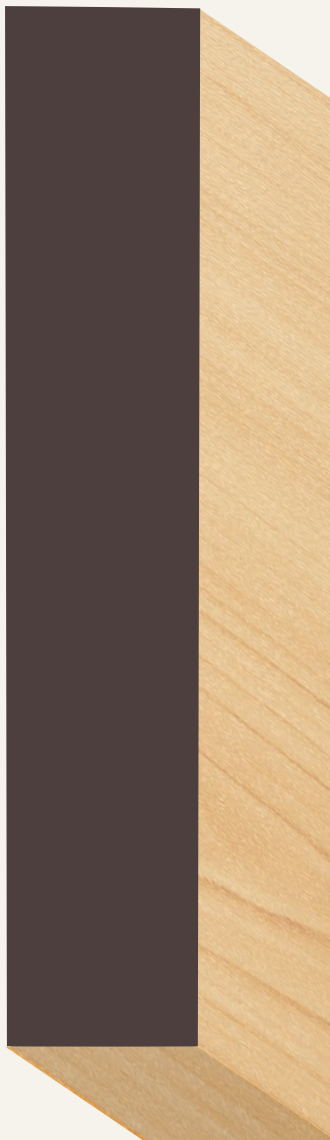

**S4S Square
Edge Headers**



1 x 4-1/2

KALD5445 KNOTTY ALDER

1 x 5-1/2

KALD5455 KNOTTY ALDER

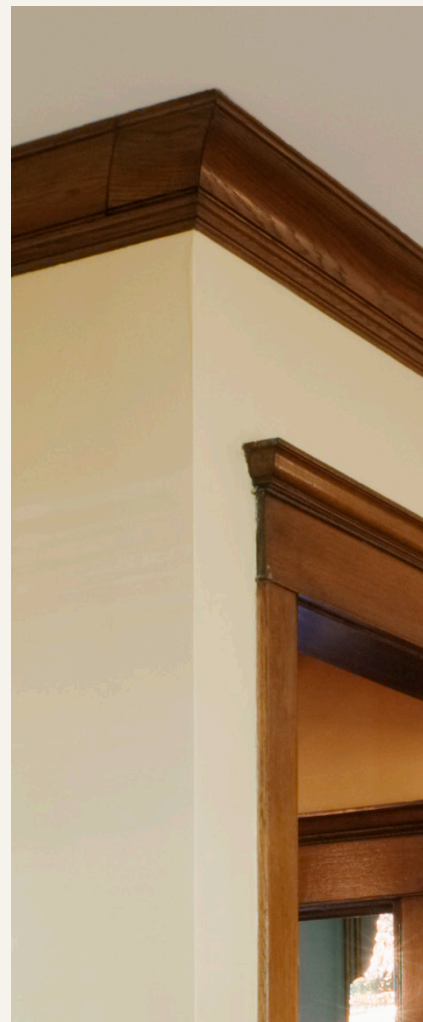

Door Accessories



Kerfed Astragal ⚙️

- 1-1/2 x 2-7/8
- F204K7** DOUG FIR (7')
- F204K8** DOUG FIR (8')

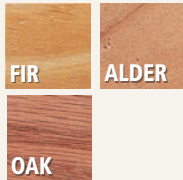

- 1-5/16 x 3
- O204K8** OAK (8')

- 1-3/8 x 3
- ALD204K8** ALDER (8')
- POP204K8** POPLAR (8')

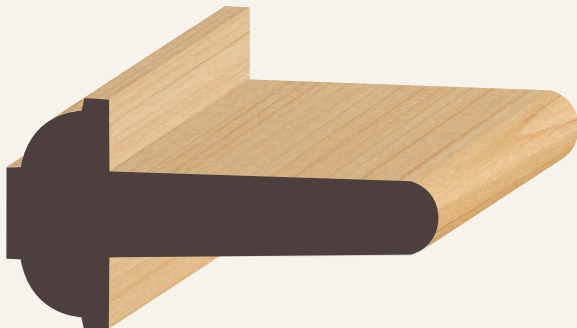

Astragal (⚙️ 7' & 8')

- 1-1/2 x 2 (for 1-3/8" Door)
- PT202FJ** RAW FJ PINE

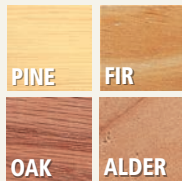

- 1-5/16 x 2 (1-3/8" Door)
- F202** DOUG FIR
- O202** OAK

- 1-5/16 x 2-1/4 (1-3/4" Door)
- F204** DOUG FIR
- O204** OAK

- 1-1/2 x 2-1/2 (1-3/4" Door)
- ALD2048** ALDER (8')



⚙️ Available in Cut to Length)

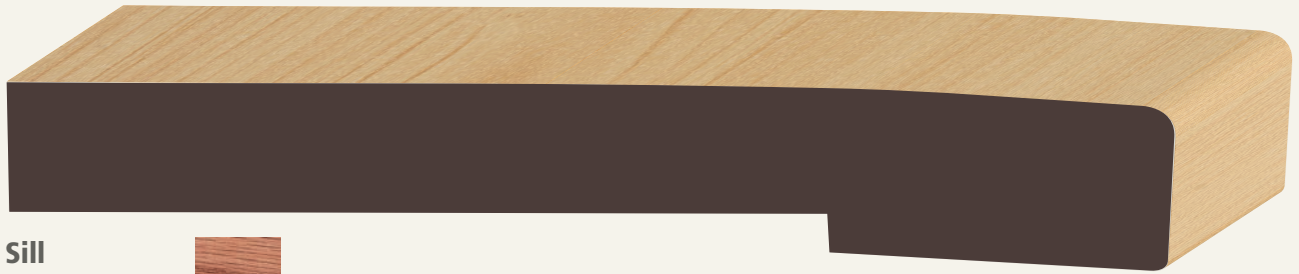

Sill

1-1/16 x 5-1/4

OSILL5 OAK

1-1/16 x 7-1/4

OSILL7 OAK



(90% of actual size)



Threshold

5/8 x 3-5/8 x Random Lengths and 37"

OTHRES-4 OAK



Threshold

5/8 x 4-5/8 x Random Lengths and 37"

OTHRES-5 OAK

1-1/16 x 5-5/8 x Random Lengths and 37"

OTHRES-6 OAK



Window Sash Stool (Lineal)

Size:		
11/16 x 4-1/2	SOLID PINE	P374
11/16 x 5-1/4	VG DOUG FIR	VG1376
11/16 x 5-1/4	OAK	O376
11/16 x 5-1/2	SOLID PINE	P376
11/16 x 7-1/4	OAK	O377

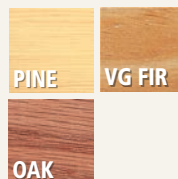

Stops and Trim



R.E. Stop

7/16 x 7/8

P346 SOLID PINE



7/16 x 1-1/8

P348 SOLID PINE

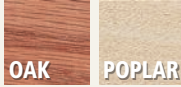

7/16 x 1-1/4

P349 SOLID PINE ⚙️

VG349 VG DOUG FIR ⚙️

O349 OAK ⚙️

POP349 POPLAR (⚙️ ONLY)



R.E. Stop

7/16 x 1-3/8

P350 SOLID PINE ⚙️

C625 CEDAR



7/16 x 1-5/8

P352 SOLID PINE



1/2 x 1-1/2

ALD439 ALDER (8' ⚙️ ONLY)

POP439 POPLAR (8' ⚙️ ONLY)

7/16 x 2-1/4

P356 SOLID PINE

1/2 x 2-1/4 (Garage Stop)

POP110 POPLAR



Colonial Stop

7/16 x 1-3/8

P357 SOLID PINE



Batten S1S2E

5/16 x 2-1/2

C603 CEDAR



O.G. Stop

7/16 x 1-3/8

P358 SOLID PINE



1/2 x 1-1/2

ALD359 ALDER(8' ⚙️ ONLY)

POP359 POPLAR ⚙️



(⚙️ Available in Cut to Length)

Stops and Trim

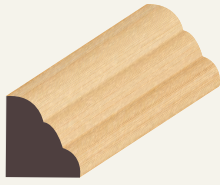

Glass Bead

3/8 x 3/8

P296 SOLID PINE

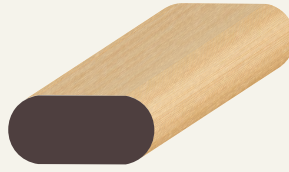

Parting Bead

3/8 x 3/4

P320 SOLID PINE



Alpine Bead

7/16 x 1-1/8

VG1337 VG DOUG FIR



Beaded Screen

1/4 x 3/4

P342 SOLID PINE



Flat Screen

1/4 x 3/4

P340 SOLID PINE

O340 OAK

ALD340 ALDER



Scribe Mould

3/16 x 3/4

ALD593 ALDER



Flat Screen

1/4 x 1/2

P338 SOLID PINE



Stops and Trim



Cove

1/2 x 1/2

P272 SOLID PINE

11/16 x 11/16

VG1274 VG DOUG FIR

C606 CEDAR

3/4 x 3/4

P274 SOLID PINE

O274 OAK

ALD274 ALDER

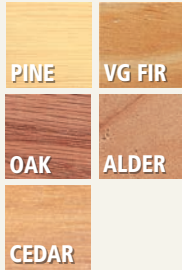

Sprung Cove

11/16 x 1-3/4

P276 SOLID PINE

11/16 x 2-1/4

P278 SOLID PINE



Lino Cove

5/8 x 1-1/2

P280 SOLID PINE



Decorative Cove

3/4 x 3/4

P275 SOLID PINE

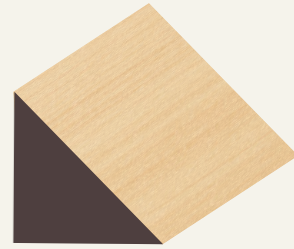

Chamfer Strip

3/4 x 3/4

P264 SOLID PINE

1" x 1"

P264-1 SOLID PINE

1-1/2 x 1-1/2

P264-2 SOLID PINE



Corner Guard

3/4 x 3/4

P266 SOLID PINE

O266 OAK

1 x 1

P268 SOLID PINE

ALD268 ALDER

1-1/8 x 1-1/8

O269 OAK

1-3/8 x 1-3/8

P270 SOLID PINE

1-1/2 x 1-1/2

C604 CEDAR

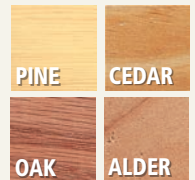

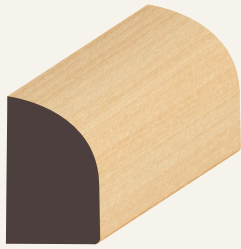

Base Shoe

1/2 x 3/4

P226 SOLID PINE

O226 OAK

ALD226 ALDER

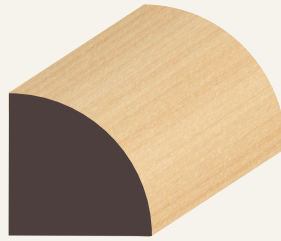
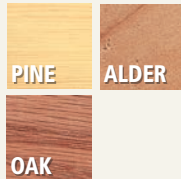

Quarter Round

1/4 x 1/4

P324 SOLID PINE

3/8 x 3/8

P326 SOLID PINE

1/2 x 1/2

P328 SOLID PINE

O328 OAK

ALD328 ALDER

5/8 x 5/8

P330 SOLID PINE

11/16 x 11/16

VG1332 VG DOUG FIR

C614 CEDAR

3/4 x 3/4

P332 SOLID PINE

O332 OAK

ALD332 ALDER

1 x 1

P334 SOLID PINE

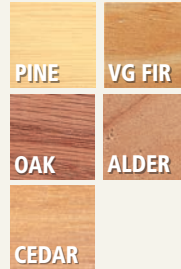

Half Round

1/4 x 1/2

P298 SOLID PINE

5/16 x 5/8

P300 SOLID PINE

3/8 x 3/4

P302 SOLID PINE

O302 OAK

ALD302 ALDER

1/2 x 1

P304 SOLID PINE

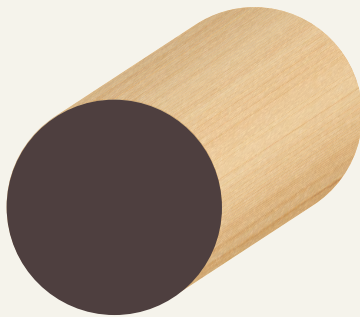
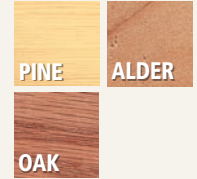

Full Round - Poles

1-5/16

F502 DOUG FIR

F502FJ FJ DOUG FIR

1-3/8

F503 DOUG FIR

1-9/16

F504 DOUG FIR

F504FJ FJ DOUG FIR

1-9/16

F504R (Return) DOUG FIR

SEE HANDRAIL SECTION

3-1/4

F504ROS (Rosettes) DOUG FIR

SEE HANDRAIL SECTION

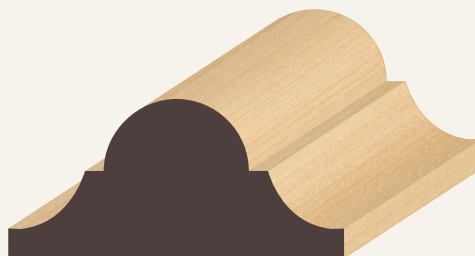

Beauty/Panel Mould

5/8 x 1-7/16

P295 SOLID PINE

ALD130 ALDER

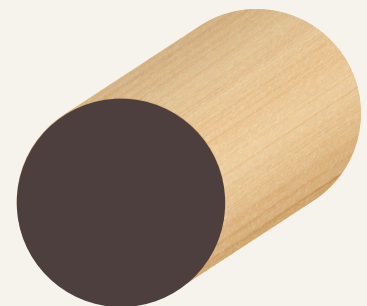

Full Round

3/4"

P288 SOLID PINE

1"

P290 SOLID PINE

1-3/4"

P294 SOLID PINE

O294 OAK



Miscellaneous



Nosing

1-1/16 x 3-1/2 x 3/4
0397 OAK



1-1/16 x 3-1/2 x 5/16
0399 OAK

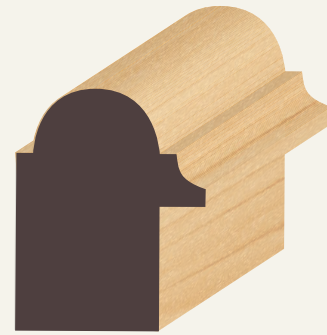

Back Band

1-3/8 x 1-1/16
ALD022 ALDER



Bead & Cove Nosing

1 x 1-5/8
ALD571 ALDER



Panel Mould

9/16 x 3/4
ALD177 ALDER

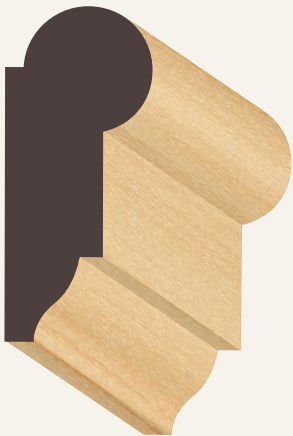

Picture Mould

3/4 x 1-3/4
P322 SOLID PINE



Basecap

9/16 x 3/4
P224 SOLID PINE



Caps



Wainscot Cap

7/16 x 1-3/8

P378 SOLID PINE



Coronado Cap

11/16 x 1-3/8

P384 SOLID PINE



Panel Cap

1-1/8 x 1-3/16

ALD030 ALDER



Cap Mould

9/16 x 1-1/8

P230 SOLID PINE



3/4 x 2

P231 SOLID PINE



Wainscot Cap

9/16 x 2-1/4

ALD53 ALDER



Cap

1-3/16 x 2-3/16

ALD023 ALDER



Wainscot



Wainscoting

3/8 x 3-1/2

ALD134 ALDER

5/8 x 3-1/8

KALD1x4TG KNOTTY ALDER



Smooth Wainscot

3/4 x 4-5/8

KALD1x5TG KNOTTY ALDER



Wainscot Base

9/16 x 5

ALD55 ALDER



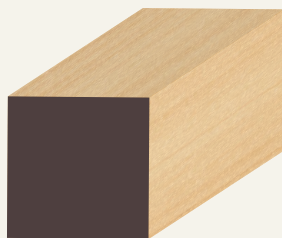

Square

1/2 x 1/2

P368 SOLID PINE



11/16 x 11/16

C626 CEDAR



3/4 x 3/4

P370 SOLID PINE

1 x 1

P371 SOLID PINE

1-1/2 x 1-1/2

P372 SOLID PINE



S4S Trim

1/2 x 3/4

P360 SOLID PINE

1/2 x 1-1/2

P518 SOLID PINE

1/2 x 2-1/2

P519 SOLID PINE

1/2 x 3-1/2

P520 SOLID PINE

1/2 x 5-1/2

P522 SOLID PINE

11/16 x 1-5/8

P362 SOLID PINE

5/16 x 1-3/4

P316 SOLID PINE

5/16 x 2-1/4

P318 SOLID PINE

11/16 x 2-1/2

P364 SOLID PINE

3/4 x 3-1/2

P366 SOLID PINE



Lattice

5/16 x 1-1/8

P312 SOLID PINE

5/16 x 1-3/8

P314 SOLID PINE

C610 CEDAR

5/16 x 1-5/8

C612 CEDAR



Brick Mould

1-1/4 x 2

O381 OAK



1-1/8 x 2

ALD381 ALDER



Rabbet Shelf Cleat

11/16 x 1-5/8

P344 SOLID PINE



Handrail and Pole

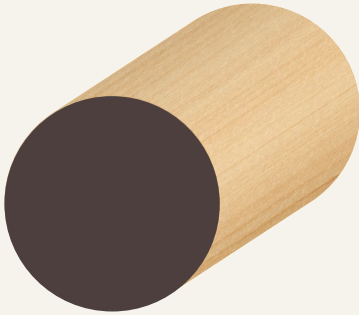

Fir Full Round



- F502 1-5/16 x 1-5/16
- F502FJ 1-5/16 x 1-5/16 (Fingerjointed)
- F503 1-3/8 x 1-3/8
- F504 1-9/16 x 1-9/16
- F504FJ 1-9/16 x 1-9/16



Flat Bottom Handrail



- 1-1/2 x 1-11/16
- F505FJ FJ DOUG FIR
- 1-1/2 x 1-11/16
- C505 CEDAR



Mushroom Handrail

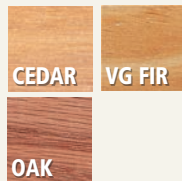

- 1-7/16 x 1-15/16
- C501 CEDAR
- F501 DOUG FIR
- 1-3/8 x 2-1/4
- F506 DOUG FIR
- F506FJ FJ DOUG FIR
- 1-5/8 x 2-3/8
- O506 OAK

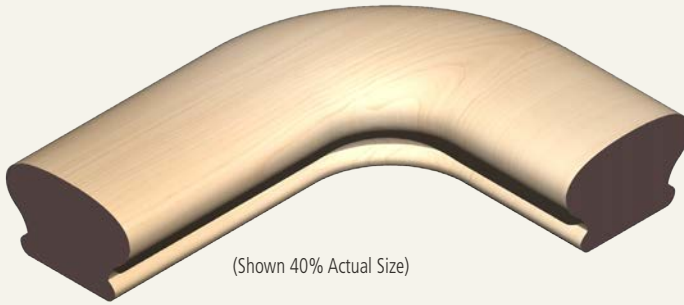

(Shown 40% Actual Size)

Fir Handrail Return

1-7/16 x 1-15/16

F501R DOUG FIR

1-3/8 x 2-1/4

F506R DOUG FIR

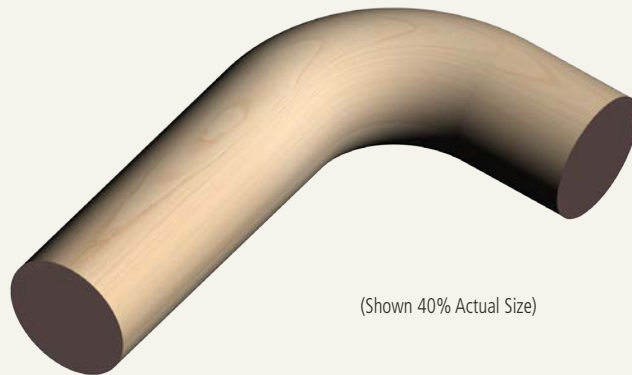

(Shown 40% Actual Size)

Fir Full Round Return

F504R 1-9/16 x 1-9/16



(Shown 40% Actual Size)

**Fir Full Round Rosette
for 1-5/8" Return**

F504ROS 3-1/4 x 3-1/4



S4S Boards

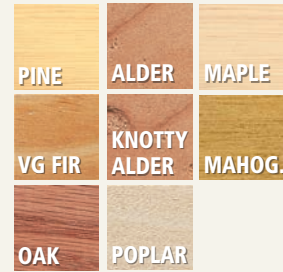

S4S Boards (Nominal Sizes. Please see website for actual dimensions)

Size:	Solid Pine	VG D Fir	Oak	Maple	African Mahogany	Alder	Knotty Alder	Poplar
1x2	P362	F1x2xR	O1x2xR					PO1x2xR
1x3	P364	F1x3xR	O1x3xR			ALD1x3xR		PO1x3xR
1x4	P366	F1x4xR	O1x4xR	MP1x4xR	AM1x4xR	ALD1x4xR	KALD1x4xR	PO1x4xR
1x5								
1x6	P1x6	F1x6xR	O1x6xR	MP1x6xR	AM1x6xR	ALD1x6xR	KALD1x6xR	PO1x6xR
1x8	P1x8	F1x8xR	O1x8xR	MP1x8xR	AM1x8xR	ALD1x8xR	KALD1x8xR	PO1x8xR
1x10	P1x10	F1x10xR					KALD1x10xR	PO1x10xR
1x12	P1x12	F1x12xR	O1x12xR	MP1x12xR	AM1x12xR		KALD1x12xR	PO1x12xR
2x4		F2x4xR						
2x6		F2x6xR						
2x8		F2x8xR						
2x12		F2x12xR						



Jambstock

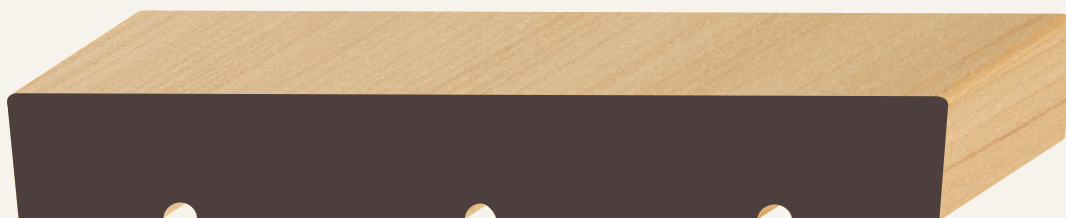

Jambstock (Please see website for additional dimensions)

Size:	Species:	Lineal:	Pairs:	8' Pairs:
4-9/16"	SOLID PINE	P308	PJ308SP	PJ308SP-96
"	VG DOUG FIR	VG408	VG408SP	VG408SP-96
"	ALDER	N/A	ALD308SP	ALD308SP8
"	SUPERIOR ALDER	N/A	N/A	CALD308SP8
"	OAK	O308S	O308SP	N/A
"	POPLAR	N/A	POP308SP	POP308SP8
4-13/16"	SOLID PINE	N/A	PJ309SP	N/A
"	VG DOUG FIR	N/A	VG409SP	N/A
"	ALDER	N/A	ALD309SP	ALD309SP8
"	POPLAR		POP309SP	POP309SP8
5-1/4"	SOLID PINE	P310	PJ310SP	N/A
"	VG DOUG FIR	N/A	VG410SP	VG410SP-96
"	ALDER	N/A	ALD310SP	ALD310SP8
"	SUPERIOR ALDER	N/A	N/A	CALD310SP8
"	OAK	O310	O310SP	N/A
"	POPLAR	N/A	N/A	POP310SP8
6-1/2"	SOLID PINE	N/A	PJ311SP	N/A
7-1/4"	SOLID PINE	N/A	PJ312SP	PJ312SP-96
"	VG DOUG FIR	N/A	VG312SP	VG312SP-96
"	ALDER	N/A	ALD312SP	ALD312SP8
"	SUPERIOR ALDER	N/A	N/A	CALD312SP8
"	POPLAR	N/A	N/A	POP312SP8
9-1/4"	KNOTTY ALDER	N/A	N/A	ALD316SP8



INTERIOR JAMB SPECIFICATIONS:

81" below dado. No lug. Dado depth 5/16".

Heads cut 5/8" over opening.

Jamb and Framestock

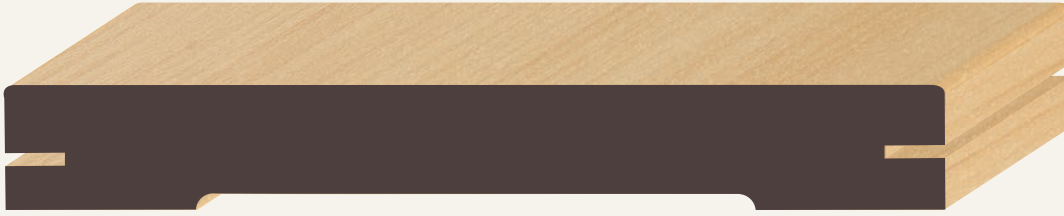

Interior Kerfed Jambstock

Size:	Species:	Lineal:	Pairs:	8' Pairs:
3-1/2"	ALDER	N/A	N/A	ALD306SKP8
"	SUPERIOR ALDER	N/A	N/A	CALD306SKP8



INTERIOR JAMB SPECIFICATIONS:

81" below dado. No lug. Dado depth 5/16".
Heads cut 5/8" over opening.

Note: Jambs and frames are available in a wide variety of sizes, wood species, and pre-cut 7' or 8' lengths. Please ask your sales representative for item numbers and availability.



Exterior Frame Stock (PLEASE SEE WEBSITE FOR ADDITIONAL DIMENSIONS)

Size:	Rabbet:	Species:	Lineal:	Pairs:	8' Pairs:
4-5/8"	1/2 x 1-13/16	SOLID PINE	N/A	PF806SP	N/A
"	1/2 x 1-13/16	VG DOUG FIR	N/A	VG806SP	N/A
5-1/4"	1/2 x 1-13/16	SOLID PINE	P816	PF816SP	N/A
"	1/2 x 1-13/16	VG DOUG FIR	F517	VG816SP	VG818SP
"	1/2 x 1-13/16	OAK	O816	O816SP	N/A
6-5/8"	1/2 x 1-13/16	SOLID PINE	N/A	PF721SP	N/A
7-1/4"	1/2 x 1-13/16	SOLID PINE	P726	PF726SP	N/A
"	1/2 x 1-13/16	VG DOUG FIR	F516	VG726SP	VG728SP
"	1/2 x 1-13/16	OAK	O726	O726SP	N/A



EXTERIOR FRAME SPECIFICATIONS:

82-1/2" below dado. Single end dado 1-1/4" for head. No lug.
Eased face corners. No sill dado. Heads rough cut 37".



Kerfed Exterior Frame Stock (Please see website for additional dimensions)

Size:	Rabbet:	Species:	Lineal:	Pairs:	8' Pairs:
4-5/8	1/2 x 2-3/16	SOLID PINE	N/A	PF806SKP	N/A
"	1/2 x 2-3/16	VG DOUG FIR	N/A	VG806SKP	N/A
"	1/2 x 2-3/16	ALDER	N/A	N/A	ALD806SKP8
"	1/2 x 2-3/16	SUPERIOR ALDER	N/A	N/A	CALD806SKP8
"	1/2 x 2-3/16	POPLAR	N/A	N/A	POP806SKP8
5-1/4	1/2 x 2-3/16	SOLID PINE	N/A	PF816SKP	PF818SKP
"	1/2 x 2-3/16	VG DOUG FIR	N/A	VG816SKP	VG818SKP
"	1/2 x 2-3/16	ALDER	N/A	N/A	ALD816SKP8
"	1/2 x 2-3/16	SUPERIOR ALDER	N/A	N/A	CALD816SKP8
"	1/2 x 2-3/16	OAK	N/A	O816SKP	N/A
"	1/2 x 2-3/16	POPLAR	N/A	POP816SKP	POP816SKP8
6-5/8	1/2 x 2-3/16	SOLID PINE	N/A	PF721SKP	N/A
7-1/4	1/2 x 2-3/16	SOLID PINE	N/A	PF726SKP	PF728SKP
"	1/2 x 2-3/16	VG DOUG FIR	N/A	VG726SKP	VG728SKP
"	1/2 x 2-3/16	ALDER	N/A	N/A	ALD726SKP8
"	1/2 x 2-3/16	SUPERIOR ALDER	N/A	N/A	CALD726SKP8
"	1/2 x 2-3/16	OAK	N/A	O726SKP	N/A
"	1/2 x 2-3/16	POPLAR	N/A	POP726SKP	POP726SKP8
9-1/4	1/2 x 2-3/16	KNOTTY ALDER	N/A	N/A	ALD856SKP8



EXTERIOR KERFED FRAME SPECIFICATIONS:

Single end dado 1-1/4" for head. No lug. Eased face corners. No sill dado.
 82-1/2" below dado, single rabbeted 1/2" x 2-3/16", kerfed for weatherstrip 1/8" x 1/2" with a 1/32" offset from the face of the rabbet.
 Fire rated products have a rating of 20 minutes.

Blocks and Corners



Beveled Edge Rosette

870OAK	1-1/16 x 2-1/2
870WHW	1-1/16 x 2-1/2
871OAK	1-1/16 x 3-1/2
871WHW	1-1/16 x 3-1/2
872OAK	1-1/16 x 4-1/2
872WHW	1-1/16 x 4-1/2

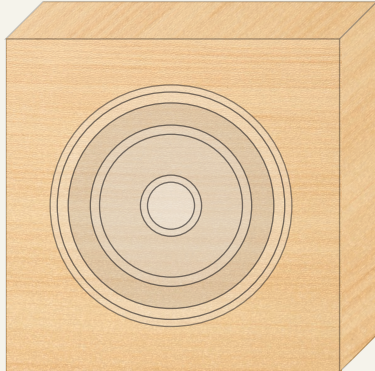

Square Edge Bulls Eye

935OAK	3/4 x 2-1/2
935WHW	3/4 x 2-1/2
935MDF	3/4 x 2-1/2
642OAK	5/8 x 2-1/2
642WHW	5/8 x 2-1/2
734OAK	27/32 x 3-1/2
734WHW	27/32 x 3-1/2
734CMDf	3/4 x 3-1/2
740OAK	27/32 x 4-1/2
740WHW	27/32 x 4-1/2



Plinth Blocks

742OAK	1-1/16 x 3-1/2 x 6-1/2
742WHW	1-1/16 x 3-1/2 x 6-1/2
742PBMDf	3/4 x 3-1/2 x 6-1/2
743WHW	1-1/16 x 4-1/2 x 8"
887WHW	27/32 x 2-1/2 x 5-3/4
888WHW	1-1/16 x 3-1/4 x 6-1/2
888OAK	1-1/16 x 3-1/4 x 6-1/2
940WHW	1-1/16 x 6-1/2 x 8"

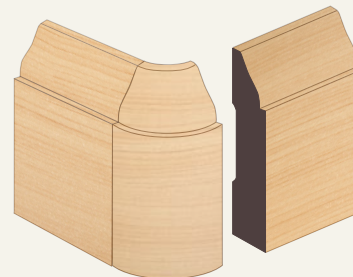

Corners and Flexible Moulding

Ask for more information

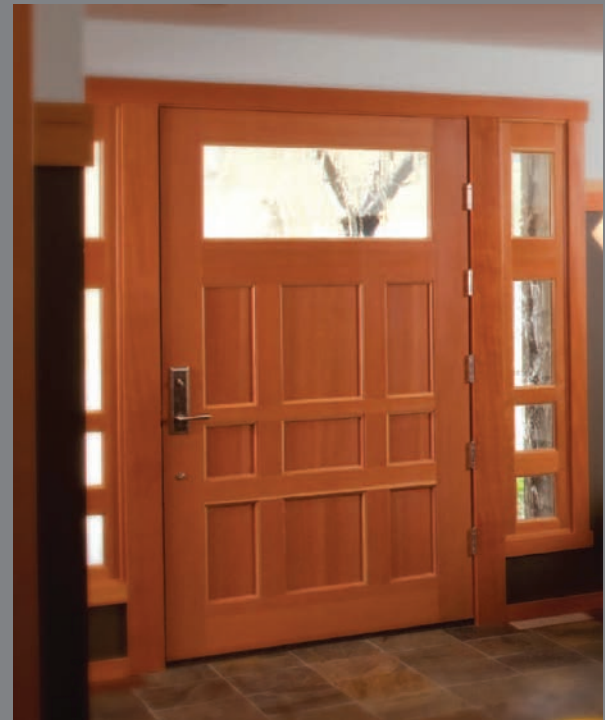

ADDITIONAL KELLEHER PRODUCTS

Advantage Plus Siding and Primed Boards

Kelleher distributes a wide selection of exterior siding to complement it's line of exterior moulding and trim. Ask your retailer for more information.

Kelleher Advantage Plus™ is a fully treated, primed Pine product that is strong, versatile, easy and safe to use. Made from a renewable resource, these products withstand a wide range of climates and come with a 30 year warranty. LOSP (Light organic solvent preservatives) are used to treat the wood making them safer to use and handle than other treated products. Kelleher Advantage Plus carries a variety of Green building certifications. Advantage Plus products are paint ready with two factory applied coatings, durable, safe for interior and exterior use, termite resistant, defect free, non-corrosive. Advantage Plus sidings are fire rated. Specially formulated End Sealer, available in spray cans, protects wood where cuts and notches are made. Finish with two coats of quality 100% acrylic paint. Kelleher Advantage Plus products are...



Kelleher Advantage primed siding and boards are a very durable product, and are suited for applications where a 30 year warranty, specifications, and certifications are not required. They are ideal for more moderate climates and may be finished with two coats of quality 100% acrylic paint.

Kelleher Primed Western Red Cedar siding and boards are made from high quality, clear, fingerjointed Western Red Cedar. Cedar is naturally resistant to rot and extreme weather, and with two coats of factory applied priming will last for several generations. Primed Western Red Cedar comes with a **30 year warranty**.

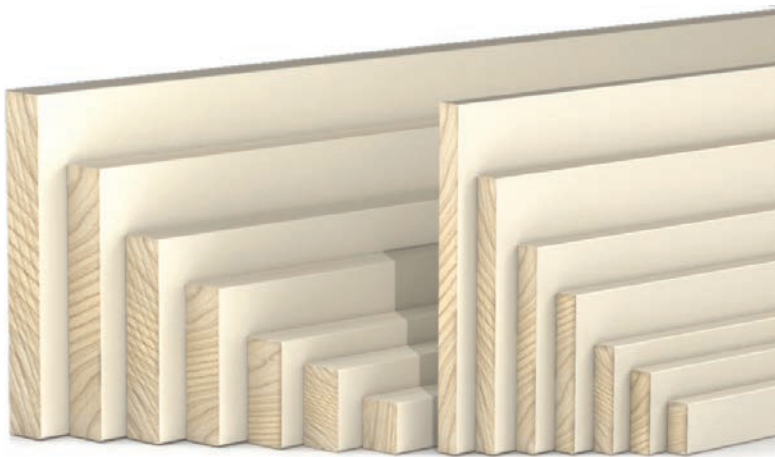

Primed boards are S3S (surfaced three sides) and E2E (eased two edges) for a superb look. Use for general trim, Fascia, and most above ground and non-structural applications. Finish with two coats of quality 100% acrylic paint. Available in Kelleher Advantage Plus with 30 year warranty, Kelleher Advantage primed, and Western Red Cedar.



Trim boards complement other architectural details and add detail to fascias and window casing treatments.



Sidings let you create a variety of classic home styles

Many Popular Styles

RAB Smooth Face/Resawn Back

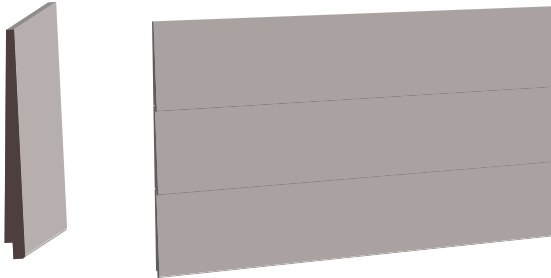

V-Rustic Siding

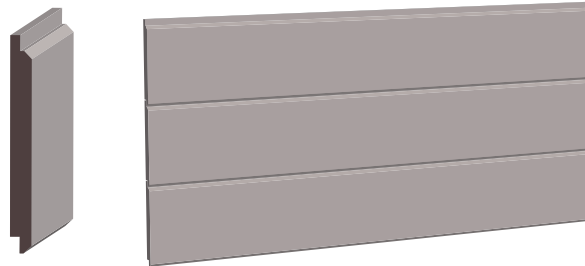

Bevel Channel

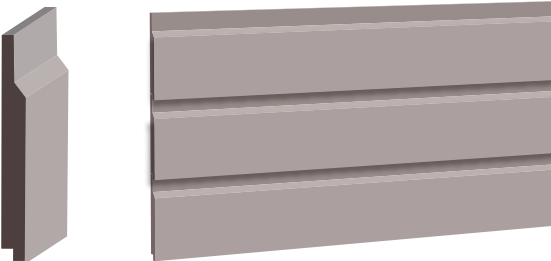

Cove Siding

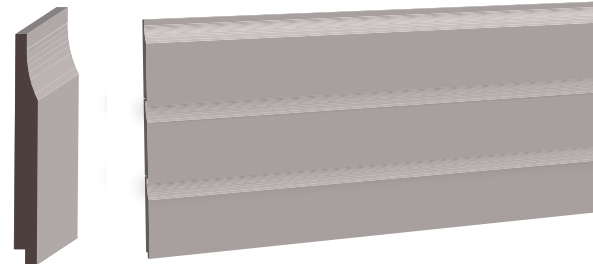

2 & 3 Lap Siding

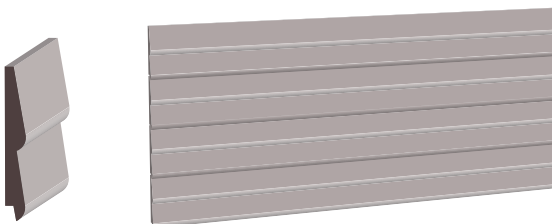

Tongue & Groove Beaded Siding/Ceiling Moulding

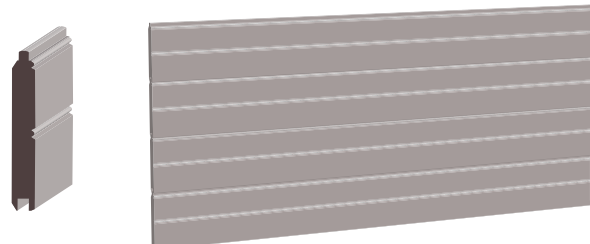

Lumber and Accessories

Furring Strips

High quality pine furring strips manufactured in Canada. All stock is lean S4S with an eased edge.

Premium Furring Strips

1 x 2 x 8

2 x 2 x 8

Advantage Boards

- 1x2 - 2x12, 16' & 20' Primed Resawn Facia
- 1x2 - 2x12 Primed Treated Resawn Facia
- 1x2 - 2x12 Primed VG FJ Cedar

Pine

- Clear Ponderosa Pine
- Common Pine
- Lodge Pole Pine Premium Furring Strips 1x2 and 2x2, 8'

Garden Products

- Full Line of Lattice Panels
- Squares
- Special Order Panels

Doug Fir

- Clear Vertical 1x2 - 2x12, 4x4 and T&G
- C and Better VG Rough Sawn

Redwood

- Clear All Heart, Aye, Heart Bee, Sap Bee, Pattern Stock
- Green Redwood (Con Heart, Heart Bee Rough and S4S)

Cedar

- VG A-Grade Cedar
- Complete Line of Split Rail Fencing
- Special Order Panels



Builder's Shims

For the leveling and squaring of building components in all kinds of construction

Uses include: setting doors and windows, installing cabinets, building concrete forms, garden stakes and kindling

SH 100 1 Carton 3/8 x 1-1/2 x 9"

Cedar Builder's Shims

SH 600

3/8 x 1-1/2 x 16"

42 per bundle

Flexible Mouldings

DURAFLEX™ The Original Flexible Moulding, and Xtra-Flex Wide Profiles

Duraflex™ – The Original Flexible Moulding since 1967 is an exclusive product of ResinArt. They offer 8,000 patterns and styles. Ask a sales representative for a catalog of flexible mouldings. Locate and match your actual wood moulding to the illustrated full scale drawing.

Duraflex™ is the easy economical alternative for radius installations and because of its quality, flexibility and superior longevity it is unequaled by wooden millwork.

- The appearance of real wood.
- Ease of installation using standard woodworking equipment - cut, sand, shape, and finish like wood.
- Seamless construction without lamination defects.
- Painting: Most standard paints are compatible. Primer coats are often unnecessary.
- Staining: Use a heavily pigmented stain and finish with a clear coat.
- Moisture proof. Insect proof.
- Xtra-Flex is recommended for profiles 6" or wider due to a 0% shrinkage factor.

Please see the ResinArt catalog for more information about flex limitations, ranges of movement, and how to create templates.





TURNCRAFT® Columns

Kelleher distributes a comprehensive selection of Turncraft columns.



Poly Classic® Tapered Round Columns with Tuscan Caps and Bases



Poly Classic® Tapered Round Columns with Tuscan Caps and Bases



Poly Classic® Tapered Round Columns with Tuscan Caps and Bases



Poly Classic® Duraglass Square Tapered Columns



Go for it!

Classic and Colonial Columns



Poly Classic® Round and Square Columns



Wood Colonial Round and Square Columns

Craftsman Columns



Square Tapered and Non Tapered Columns



Poly Classic® Tapered Round Columns with Tuscan Caps and Bases



Ionic (above) Corinthian (below), Doric and Tuscan (left and far left) ... We have all classic styles available..

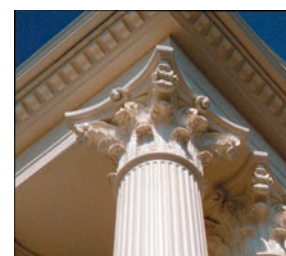

Ask your retailer for more information.

Doors



www.roguevalleydoor.com

One of America's largest builders of wood doors. FSC Certified.



Rogue Valley Door is one of America's largest builder of wood doors. Located in Southern Oregon among the towering Douglas firs and Ponderosa pines, they take pride in their modern manufacturing facility, and people that take pride in each and every door they make. Rogue Valley's beaded panel doors demonstrate their handcrafted quality workmanship, and incorporate such details as ornate beaded or true v-groove panels, highlighting the natural luster of these fine wood doors and adding style and dimension to your home's interior design.



ADDITIONAL KELLEHER PRODUCTS